

Troubleshooting a Refinery Fuel Gas Treater: A Case Study*

*Nathan A. Hatcher & Alfred E. Keller
ConocoPhillips Company
Ponca City, Oklahoma*

*Ralph H. Weiland M. S. Sivasubramanian
Optimized Gas Treating, Inc. Optimized Gas Treating, Inc.
Clarita, Oklahoma Wayland, Massachusetts*

SUMMARY

The effect of solvent contaminants on treating plant performance, and the importance of basing simulations on actual solvent analyses are demonstrated through the successful troubleshooting of an MDEA-based fuel-gas H₂S treating system.

Introduction

Commercial software packages for amine plant simulation use column models that range from simple equilibrium stages, equilibrium stages modified for reaction kinetics, equilibrium stages with computed stage efficiencies, right through to true mass and heat transfer rate models. Regardless of the underlying principles on which each one is based, simulations of amine plants have traditionally assumed the solvent to be perfectly clean, meaning that it contains only water, amines, and acid gases. In some cases, the solubility of light hydrocarbons and inert gases may be taken into account. Outside the laboratory, clean solvents probably exist in most plants for only a short time immediately following initial system charging and startup.

Over time, solvents accumulate contaminants primarily from the gases being treated or through the use of makeup agents (water and amine) that are not completely pure. Contaminants of interest here are frequently the anions of organic and inorganic acids, also called heat stable salts (HSSs). Anions commonly found in amine solutions include thiosulfate, oxalate, sulfate, glycolate, propionate, acetate, thiocyanate, formate, and chloride, which usually enter the solution with the gases or liquids being treated. The use of sulfate or phosphate to enhance H₂S removal in tail gas treating units (TGTUs) is becoming increasingly common. Contaminants may also be cationic such as alkali metal ions (sodium, potassium, calcium, and magnesium) that accumulate from the result of makeup water hardness or through deliberate addition of hydroxides to deprotonate amine associated with heat stable amine salt anions. All of these ions can have profound effects, sometimes positive, sometimes negative, on the performance of amine treating units.

Chemistry

Clean solvents consist of water solutions of one or more amines together with the acid gases CO₂ and H₂S. A number of reaction equilibria are set up, all involving ionic species, and all depending on the presence of water. For a system containing a single amine together with H₂S and CO₂ in aqueous solution, five equilibrium ionic reactions involving amine occur. If the amine is either primary (R₂, R₃ = H) or secondary (R₃ = H), reaction with CO₂ will form the carbamate:

* Petroleum Technology Quarterly, p. 147, Fall Quarter, 2006

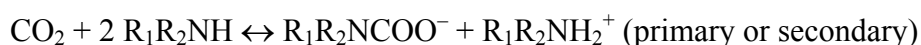
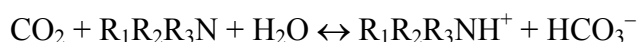
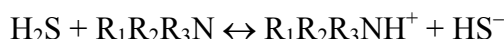
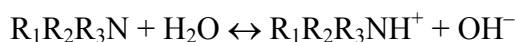

It will be useful to note that protonated amine is common to all the reactions. The thermal reversibility of these reactions makes treating with amines economically feasible. But things can go awry when gases contain certain types of components, even in seemingly quite small amounts.

After a period of use, especially in treating sour gases generated from refinery cracking operations (Cokers, FCC's), trace amounts of acid anion contaminants can build to significant levels in the solvent. The most commonly found acid anions, formate and thiocyanate, result from the absorption of hydrogen cyanide, with formate being formed by the hydrolysis of the cyanide ion to ammonium formate, and with thiocyanate being formed from dissolved oxygen reacting with H₂S followed by reaction of the oxysulfur anion with cyanide ion. Higher molecular weight organic acid anions come from the hydrolysis of higher molecular weight nitrile compounds. Ammonium ion from the hydrolysis will release H⁺ to the amine and be steam stripped in the regenerator where it accumulates in the overhead condensing system, leaving the protonated amine/HSS anion pair in the amine solution. Hydrogen from gasoline reformers can contain HCl which will directly acid-base neutralize the amine. Thiosulfates generally result from the reaction of dissolved oxygen with H₂S or from SO₂ reaction with H₂S in Claus tail gas units when no HCN is present. Sulfates can be formed either from absorption of sulfuric acid or from further oxidation of thiosulfates. These are shown in the following reactions:

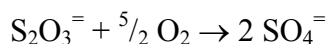
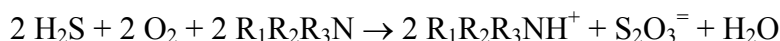
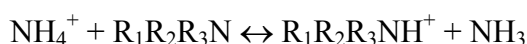

For a strong acid H_nX where X is an n-valent anion (Cl⁻, SO₄²⁻, etc.) the reaction with amine is

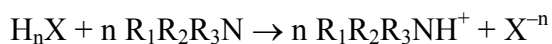

Unlike the acid gas-amine reactions, reactions with HSSs are not *thermally* reversible (thus the term heat stable salt), so the HSSs permanently tie up part of the amine as $R_1R_2R_3NH^+$ ion¹. The fact that the amine is gradually degraded to HSAS and becomes inactivated is bad enough. But far more worrying is its effect on the ability to regenerate the rich solvent to satisfactory acid gas lean loadings (moles of acid gases per mole of total amine) and to use the regenerated solvent effectively in the absorber². Heat stable salt anions are also known to complex iron ion and accelerate corrosion in the hot, lean section of the amine unit. Iron sulfide particles are formed when the complexed iron contacts higher concentrations of H_2S in the absorber. These particles can foul equipment, lead to loss of treating capacity, and further exacerbate corrosion by eroding the protective iron sulfide film on the surface of carbon steel equipment.

For a lean amine at regenerator temperatures (i.e., towards the bottom of the stripper and in the reboiler) the acid gas loadings are normally very low so the concentrations of HS^- , HCO_3^- and $R_1R_2NCOO^-$ are small. This means that in a clean solvent, the concentration of protonated amine is quite small, too. However, when the solvent becomes increasingly contaminated with acid anions that are stronger than HS^- and HCO_3^- , the concentration of protonated amine at the regenerator's lean end is determined by the extent of contamination. The higher protonated amine concentration drives the bisulphide and bicarbonate-forming reactions strongly to the left. This is *beneficial to regeneration* because it produces greater driving force for the decomposition reaction. Thus, all other conditions being the same, from a mass transfer and phase equilibrium viewpoint, *solvent contaminated with relatively strong-acid is always easier to regenerate than a clean solvent!* There is a catch, however.

Increased protonated amine also drives these same reactions to the left under absorption conditions. Again, at the same temperature, total amine concentration, and acid gas loadings, a contaminated lean solvent entering an absorber will always exhibit greater acid gas partial pressures than a clean one. Acid contamination is *detrimental to absorption*. So, it depends very much on the exact conditions of operation as to whether the benefit contamination brings to regeneration outweighs its penalty to absorption.

With increasing time-on-stream, acidic contaminants continue to build until a point is reached where something must be done to recover the permanently-neutralized bound amine to restore free amine circulation capacity, to prevent the amine unit from self-destructing through corrosion, or to enable the plant to achieve the specification on treat again.

To understand and simulate quantitatively the effect of HSSs on treating performance, one must be able to model the regenerator with just as much confidence and accuracy as the absorber—the regenerator sets lean solution quality, the main controlling factor at the lean end of the absorber where the ability to treat is determined. As will become evident, it is equally crucial to account for ionic contaminants and to use a comprehensive solvent analysis.

¹ The ionic compound $R_1R_2R_3NHX$ is often referred to as a **Heat Stable Amine Salt (HSAS)** even though it exists only in the fully *dissociated* form $R_1R_2R_3NH^+ + X^-$ in aqueous solution.

² It turns out that these acidic components (HSSs) are actually very effective *regeneration enhancers*. Although their presence in solution is inherently detrimental to *absorption*, the benefit to regeneration outweighs the penalty to absorption.

HSS Contamination of a Refinery Fuel Gas Treater

A refinery MDEA fuel gas treater was experiencing a steady decline in treating performance. Prior to February, 2005, the amine contactor was consistently treating H₂S down to levels of 1–3 ppmv in the vent gas. From February to May of 2005, the H₂S gradually increased to around 17 ppmv in the treated gas. After ruling out foaming as a cause, and that lean/rich exchanger leaks were not present, the plant contacted their corporate Treating/Sulfur Processing Network for troubleshooting and simulation assistance.

Figure 1 provides an overview of the amine system together with some data pertinent to the May, 2005 operation (see Table 3). It was fortuitous that this particular unit was well instrumented. A number of the absorber trays contain thermocouples located in the liquid flow path to establish an internal temperature profile. The rich amine temperature is also known allowing the absorber energy balance to be used to reconcile the plant data. The amine loading change across the regenerator can also be found from the rich amine flow to the regenerator, metered acid gas rate, and amine disposition.

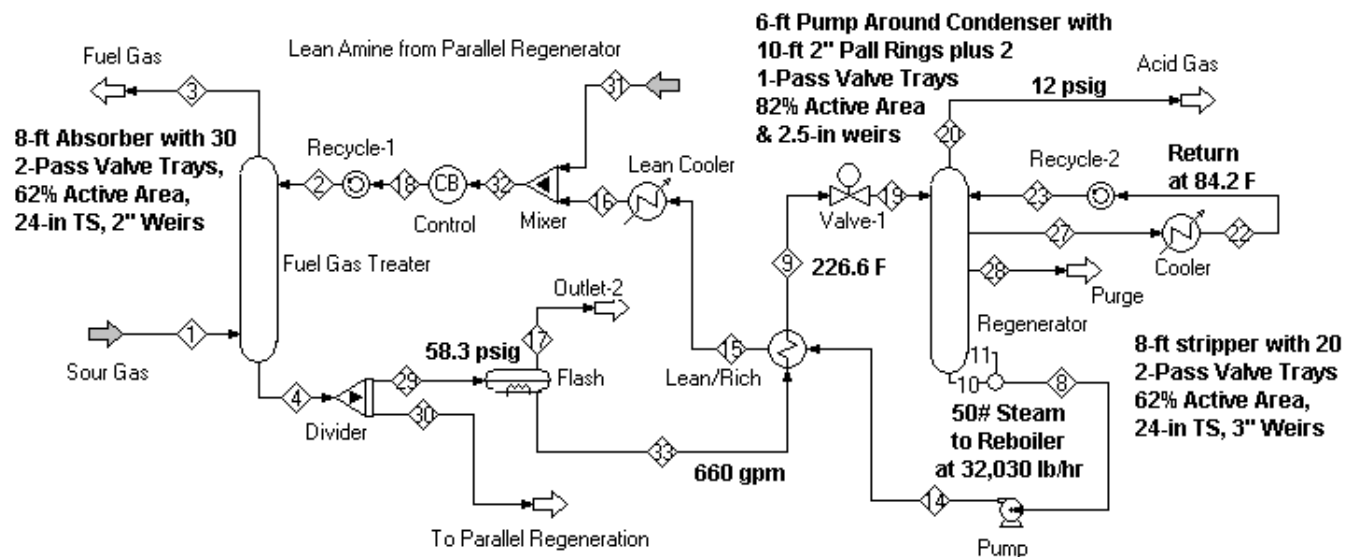

Figure 1 PFD of Fuel Gas Circuit

Table 1 presents a summary of the absorber feeds and operational data. To facilitate the troubleshooting effort, a bomb sample of the feed gas was caught for analysis by gas chromatography. Lean and rich amine samples were also taken concurrently for strength and acid gas loading analysis. Table 2 provides further analytical breakdown of the lean amine solution over time from ion chromatography analysis. In looking at just the data in Tables 1 and 2, a number of explanations could be formulated to explain the deterioration in performance, among them:

- Absorber was overloaded and therefore was rich-amine-loading pinched,
- Lean amine feed temperature increased as ambient temperature climbed from February to May,
- Regenerator performance declined as indicated by the lean loading increase. This could have been caused by tray damage, exchanger fouling, lower reboiler heat input, or decreased heat stable salts.

Table 1 Absorber Feed and Treating Performance Summary

Parameter	May 2005 Operations		February 2005 Operations	
	Absorber Feed Gas	Absorber Treated Gas	Absorber Feed Gas	Absorber Treated Gas
Temperature (°F)	100.5	115.3	99–100	108–110
Pressure (psig)	174.3	172.4	176	178
Flowrate (MMscfd)	54.5	Not Available	53.5–55.5	Not Available
Composition (Dry Mole %)	Lab GC	Online GC	Lab GC	Online GC
H ₂ S	17.04	17 ppmv	Not Available	1–3 ppmv
CO ₂	1.21	0.104	Not Available	0.11–0.12
H ₂	11.04	17.7	Not Available	20.4–20.8
N ₂	3.65	3.25	Not Available	2.5–2.7
CH ₄	39.28	49.3	Not Available	46.5–46.9
C ₂ H ₄	3.43	4.1	Not Available	4.8–5.0
C ₂ H ₆	15.02	17.0	Not Available	16.8–17.0
C ₃ H ₆	1.98	2.37	Not Available	2.8–2.9
C ₃ H ₈	3.18	3.94	Not Available	2.8–3.0
C ₄ ⁺	2.47	2.18	Not Available	2.4–2.5
Lean Amine				
Flowrate (gpm)	847–853		766–772	
Lean Loading (mole/mole)				
H ₂ S	0.0046		0.0007–0.0010	
CO ₂	0.0009		Not Available	
Total	0.0055		Not Available	
Temperature (°F)	115		108.6–110.0	

Table 2 Lean Amine Analyses by Ion Chromatography

Date of Sample:	11/10/04	12/8/04	1/12/05	2/9/05	3/9/05	4/13/05
Free amine (wt%)	40.7	42.5	37.5	40	44.1	42.3
Total amine (wt%)	42.7	44.3	38.9	41.1	45.4	43.2
Ions, ppmw						
Sodium (Na ⁺)	1,573	1,044	1,336	1,401	1,461	1,212
Formate (HCOO ⁻)	7,768	7,935	7,263	6,406	6,159	4,864
Acetate (CH ₃ COO ⁻)	885	672	605	591	370	463
Chloride (Cl ⁻)	46	87	72	54	57	42
Sulfate (SO ₄ ⁻)	0	0	0	0	0	0
Thiosulfate (S ₂ O ₃ ⁻)	38	27	60	0	43	198
Thiocyanate (SCN ⁻)	4,184	1,844	755	638	665	378
Total Anions	12,921	10,566	8,754	7,689	7,293	5,945
Cation Equiv. (meq/g)	0.2365	0.1966	0.1757	0.1533	0.1728	0.1283
Anion Equiv. (meq/g)	0.2617	0.2225	0.1878	0.1649	0.1570	0.1272
% amine as HSS	5.4	4.8	4.0	3.0	2.4	2.1
DEA (% of total amine)	0.9	1.3	1.2	1.2	0.9	1.2

The picture was complicated further by the results of initial material balance screening calculations around the absorber which showed a nominal 30% inconsistency between performance as measured by amine loadings and solvent circulation rate, and performance measured by the gas compositions and metered feed gas flow. Consequently, two sets of simulations were developed for

the system based upon the assumptions that either gas measurements or liquid measurements were correct. Table 3 presents further operating data around the absorber and principle regenerator on the circuit under these two assumptions, together with a number of simulation results.

Table 3 Simulation Comparison to May 2005 Plant Data

Parameter	May/05 Data	Simulations per GC MB			Simulations per Lab H ₂ S Loads		
		CoP	ProTreat	Other w/o HSS & Na	CoP	ProTreat	Other w/o HSS & Na
Absorber Tray No.		Tray Temperatures (°F)			Tray Temperatures (°F)		
30 (Top)	115.3	115.0	126.3	120.6	115.0	115.1	115.0
25	115.4	115.1	168.2	164.8	115.0	115.3	115.3
20	116.5	115.4	170.1	168.0	115.0	115.6	115.6
11	117.2	124.2	170.3	168.3	116.1	116.6	116.4
7	121.2	138.1	170.2	168.4	120.9	117.9	117.9
3	142.7	150.8	167.5	167.6	136.0	135.4	134.2
1 (Bottom)	144.9	155.4	155.0	155.1	144.0	149.3	147.7
H ₂ S Leak (ppmv)	17	24	17,977	15,897	24	20	29
CO ₂ slip (%)	6.9–7.6*	7.25	63.6	54.2	7.25	8.9	38.4
Lean Mole Loading	Lab						
H ₂ S	0.0046	0.0046	0.0052	0.0459	0.0046	0.0038	0.0132
CO ₂	0.0009	0.0009	0.0000	0.0016	0.0009	0.0000	0.0011
Total	0.0055	0.0055	0.0052	0.0475	0.0055	0.0038	0.0143
Rich Mole Loading	Lab						
H ₂ S	0.446	0.635	0.582	0.640	0.446	0.448	0.465
CO ₂	0.022	0.042	0.016	0.023	0.045	0.029	0.021
Total	0.468	0.678	0.598	0.663	0.491	0.477	0.486
Total per Reg MB [†]	0.46–0.47						

*per GC analysis; CO₂ slip is 33% per loading measurements

[†]Indicates total loading obtained via a material balance around the regenerator

Simulations of May operations were run for two sets of conditions using three simulation tools to evaluate the operating data. CoP is an electrolyte-based equilibrium material-balance tool developed in-house by ConocoPhillips that takes into account heat stable salt effects on treating performance. ProTreat™ (Version 3.2) is a commercial mass and heat transfer rate based amine simulator capable of accounting for the effect of HSSs and other ions on treating. It uses rigorous mass-transfer-rate calculations to evaluate absorber and regenerator performance on an actual tray basis. A third simulator, one using tray efficiencies but without the HSSs capability, was also available. It was used to demonstrate the effect of not including HSSs in simulations (only the free active amine strength was used). The sets of conditions correspond to operations that result from assuming the feed gas analysis and measured circulation rate are correct, and using:

- The *measured* feed gas flow rate (i.e., assuming it to be correct), or
- The feed gas flow rate *calculated by material balance* to give the observed rich solvent loading. (The feed gas flow necessary to achieve a material balance was some 30% lower than measured.)

Table 3 provides a direct comparison between simulation results based on assumptions (a) and (b). It is immediately apparent that using the measured gas flow in both commercial simulation packages produces a highly elevated absorber temperature profile, a hotter than measured rich amine temperature, an H₂S leak a thousand times too high (16,000 to 18,000 ppmv versus 17 ppmv measured), and a CO₂ slip roughly ten times too high (54% to 64%, versus 6.9 to 7.6% measured). On the other hand, when the gas feed rate is derived under assumption (b) above and is used in the

simulation, all three simulators show close agreement with the measured absorber temperature profile, and at least order-of-magnitude agreement with the measured H₂S leak. It is noteworthy, however, that not only did the simulations using the actual HSS and sodium contents agree much more closely with the observed H₂S leak, but *the inclusion of HSSs and sodium ion appears to have been essential to reproducing the observed CO₂ slip*. It is mentioned in passing that assuming the gas rate was correct and adjusting the solvent rate by material balance did not produce nearly as good agreement with measured data as adjusting the gas rate. The evidence is fairly convincing that the feed gas flow meter was reading some 30% high. However, we still have not explained why the treating performance deteriorated.

Using ProTreat, a sensitivity analysis was conducted to answer this question. The following variables were changed in cumulative succession from the May, 2005 calibration model to conditions corresponding to February, 2005 operations, and Table 4 shows the results.

- Lean amine temperature and to a lesser extent, feed gas temperature were dropped,
- Amine strength was raised,
- Regenerator reboiler steam was increased nominally by 10%,
- Heat stable salt and sodium ion concentrations were increased.

The results suggest that the lean amine temperature increase from February to May did not play a significant role in dictating treating performance. The higher amine strength in February would have worked in the wrong direction, increasing both the lean loading and the H₂S leak from the absorber, whereas, both were actually lower in February than in May. This suggests that the contactor's treating performance was not limited by a rich-end loading pinch. (In practice, however, the rich loading must be limited to minimize corrosion in the carbon steel equipment.) The reboiler steam rate was higher in February than in May, and ProTreat predicts that this would have a strongly positive effect on the H₂S leak and the lean loading of H₂S. However, even the increased reboiler duty is insufficient to reduce the H₂S leak to match the measured February performance. Furthermore, tower hydraulic rating indicated that the regenerator already operated close to jet flood in both February and May (~85% at 0.65 system factor), which constrains the increased steam flow that could be used to reduce emissions. But, when the HSSs and Na levels as per the detailed solution analysis were included in the solvent description, Table 4 shows that *ProTreat predicted very nearly the exact performance observed in February*. The observed H₂S leak was 1–3 ppmv versus a predicted leak of 3 ppmv; predicted 8% CO₂ slip versus 6.9–7.6% measured; predicted 0.0005 H₂S lean mole load versus 0.0007–0.001 observed lean load.

The high HSS level in February, combined with a higher reboiler steam flow, allowed the plant to produce 3 ppmv H₂S gas. *The drop in HSS level actually hurt plant performance!* The third simulation tool (without HSS and Na chemistry capabilities) completely missed both the reboiler steam benefit and the HSS effect. It also predicted a CO₂ slip some five times greater than observed.

Table 4 H₂S Treat Sensitivity Analysis—ProTreat Predictions

Case	Base May, 2005 Operation	Lower Temp	Higher Amine Strength	Higher Reboiler Steam	Higher HSS	Other Sim w/o HSS & Na
Feed Gas Temperature (°F)	100.5	100	100	100	100	100
Lean Amine Temperature (°F)	115	109.3	109.3	109.3	109.3	109.3
Reboiler Steam (lb/gal)	0.8	0.8	0.8	0.89	0.89	0.89
Total MDEA (wt%)	43.2	43.2	44.2	44.2	44.2	44.8
HSS & Na ⁺ Ions as per	May, 05*	May, 05*	May, 05§	May, 05§	Feb, 05¶	N/A Clean
Calc Lean H ₂ S Mole Loading	0.0038	0.0040	0.0054	0.0017	0.0005	0.0005
Absorber Performance						
H ₂ S (ppmv)	20	18	29	8	3	21
CO ₂ slip (%)	8.9	7.6	7.8	7.8	8.0	40.6

* May, 2005 analysis; § May, 2005 analysis increased proportional to strength; ¶ Feb, 2005 analysis

Lessons Learned

1. A simulation can only be as accurate as the data on which it is built. In this particular case study, alternative material and energy balance verification had to be performed in order to develop a realistic picture of the problem.
2. Complete solution ion chemistry must be taken into account for accurate modeling of treating down to low H₂S levels at low lean loadings. If the solvent contains contaminants, the simulation must account for each of them.
3. It is insufficient just to have an accurate absorber model. Rigorous rate-based regenerator simulation is absolutely critical to predict plant performance accurately simply because the regenerator sets the lean solution quality, and it is this that determines absorber performance.

Conclusions and Summary

Troubleshooting amine treating unit problems involves much more than simply plugging plant data into an amine plant simulation model. In the first place, amine treating chemistry is a rather complex system of ionic reactions, some thermally reversible, others not, with common ion effects. In addition, treating is often done selectively and this requires the treating operation to be analyzed as a mass-transfer-rate process—solely basing it on phase equilibrium is completely inadequate to understanding the process and the problem. *What is more, all too often an attempt is made to analyze only the operation of the absorber without recognizing that its performance hinges completely on the quality of the lean amine being produced by the regenerator.* Thus, a first rate regenerator model is at least as important as a good absorber simulation.

Careful analysis of plant and laboratory measurements can be complemented very effectively by a simulation model capable of accounting for all the details and applied to the solution of treating plant operating problems. In this case study, it quickly became evident that the complete solution ion chemistry had to be taken into account to model treating accurately down to low H₂S levels at low lean loadings. Any solvent contaminants must be included in simulations if these are to predict successfully and accurately the operation of amine plants. *Removing the HSSs actually resulted in higher H₂S leak, i.e., poorer treating.*

Material and energy balances were needed to determine the real status of the lean amine and to decide which operating parameters were reliable and which were not. All along the way, every piece of plant and laboratory information had first to be doubted, then scrutinized—virtually nothing can be taken for granted at face value. However, by applying sound chemical, physical, and engineering principles, the data were reconciled and the source of poor performance was identified and corrected.

Simulation formed an important part of these exercises. In particular, using an amine simulator capable of accounting for the effects of all the factors, including detailed solution chemistry, formed an integral part of the analyses and troubleshooting effort. In the final analysis, simulations that do not account correctly for all the ionic species may give erroneous results that can lead to unnecessary and expensive changes to plant equipment and solvents. Because this particular case study involved selective treating, the fact that the ProTreat simulator was based on sound mass-transfer-rate principles enabled the modeling to compliment the analyses. Without such a true mass-transfer-rate basis, the simulations would have been of little or no help. Furthermore, accurately simulating regeneration was critical to the successful simulation and analysis of each set of plant data.