

# Glycol dehydration of high-acid gas streams

A model based on mass and heat transfer closely predicts plant performance data for glycol dehydration of high-acid gas streams

JOHN CARROLL *Gas Liquids Engineering*

NATHAN HATCHER and RALPH WEILAND *Optimized Gas Treating*

Glycol dehydration is a process that presents some unique challenges from both technical and computational standpoints. In the first place, modern designs almost invariably use tower internals consisting of structured packing rather than the more traditional bubble cap trays. Structured packing offers a lower pressure drop and considerably higher capacity than trays, and it is well suited to handling the very low L/G ratios common in dehydration. However, until now, the height of the packing was estimated using rules of thumb, not good engineering science. Mass transfer rate-based modelling, on the other hand, uses science and therefore offers greater reliability of design. The other challenge of dehydration using any glycol is thermodynamic: water is the component of interest but it is probably nature's most perversely non-ideal chemical, which makes it challenging to devise a truly accurate model for the vapour-liquid equilibrium, especially in systems with a high-acid gas content.

Traditionally, sweetened gases have been the main candidates for dehydration, mostly using triethylene glycol (TEG) prior to entering the transmission pipelines. More recently, there has been much interest in sour gas injection as a means of disposing of gas streams of too low quality for sulphur recovery. In the context of carbon capture, the recovered CO<sub>2</sub> is compressed, liquefied and injected into underground formations. Handling these sour and high CO<sub>2</sub> streams requires dehydration prior to compression and/or liquefaction.

There are other facets of glycol dehydration that are interesting just from an applied science viewpoint. One of them is the heat transfer situation that ensues in a regenerator using both stripping gas and a reboiler (Stahl column). When the hot gas hits the bottom of the packing in the wash section atop the column, it finds itself suddenly going from an environment in which it is saturated with water in equilibrium with a predominantly TEG stream into an environment where it is grossly under-saturated with respect to the pure water stream in the wash section. This causes extremely rapid humidification, and the humidification process extracts the necessary heat of vapourisation as sensible heat from the liquid water phase. Sudden humidification can drop the wash water temperature by 30–40°F or even more.

This article addresses the efficacy of a new mass and heat transfer rate-based model in terms of how well it reflects known phase behaviour and how closely it predicts known plant performance data using both bubble cap trays and packed columns without recourse to height equivalent to a theoretical plate (HETP) or height of transfer units (HTU) estimates and other rules of thumb.

## Phase equilibrium

Our phase equilibrium concerns are twofold: accurate calculation of the equilibrium water content of high- and low-pressure gases containing very high levels of CO<sub>2</sub> and/or H<sub>2</sub>S; and calculation of the solubility of all gases, including water, in the dehydration solvent itself. These

two topics are inter-related because both require the accurate assessment of the interactions between components in the vapour phase; however, the solubility calculation is more demanding.

Normally, to model the solubility of a gas in a liquid, one uses the Henry's Law approach. A thermodynamically complete version of Henry's Law<sup>2,3</sup> is:

$$\bar{a}_i x_i H_{ij} \exp \left[ \frac{\bar{v}_i^\infty (P - P_j^0)}{RT} \right] = y_i P \hat{\phi}_i^v \quad (1)$$

where

$\gamma_i$ : Activity coefficient

$x_i$ : Mole fraction of component  $i$  in the solvent (its solubility)

$H_{ij}$ : Henry's constant for solute  $i$  in solvent  $j$ , kPa/mol frac

$\bar{v}_i^\infty$ : Partial molar volume of insolvent  $j$  at infinite dilution, m<sup>3</sup>/kmol

$P_j^0$ : Vapour pressure of the solvent, kPa

$P$ : Total pressure, kPa

$R$ : Universal gas constant, 8.314 kJ/kmol·K

$T$ : Absolute temperature, K

$y_i$ : Mole fraction of component  $i$  in the vapour

$\hat{\phi}_i^v$ : Fugacity coefficient for component  $i$  in the vapour, unitless

Most people believe that Henry's Law is only applicable to dilute solutions, but the form in Equation 1 can be applied without restriction. It would be unusual to do so, but this equation can even be applied to mixtures that are not typically considered to refer to the solubility of a gas in a liquid at all; for example, methanol and water.

Saturated water content of gases

GPSA ref.	Mole % (dry basis)			Temp, °F	Pres, psia	H <sub>2</sub> O lb/MMscf	
	CH <sub>4</sub>	CO <sub>2</sub>	H <sub>2</sub> S			Meas'd	ProTreat
Ex 20-1	100	0	0	150	1000	220	216
Ex 20-2	80	20	0	160	2000	172	188
Fig 20-9	0	100	0	100	500	132	125.3
					750	110	102.5
					1000	125	100.7
					2000	215	215.1
					3000	238	247.8
					850	88	96.9
Fig 20-16	5.31	94.69	0	100	1125	81	99.2
					1500	128	148.6
					2000	139	184.2
					2000	40.6	41.1
					1000	286	283.9
					2000	40.6	45.1
					1000	282	292.5
					2000	172	188.5
					1500	111	103.5
					1367	247	252.6
					1000	292	293.4
					1100	81	81.2
					1900	442	264.4
					1500	109.2	95
2000	164.6	234.5					

Table 1

The value of the Henry's constant is a function of both the solute and the solvent. Thus, the Henry's Law constant,  $H_{ij}$ , is different for methane in water than it is for methane in methanol, and  $H_{ij}$  is different still for ethane in water. Furthermore, for every solute-solvent pair, the  $H_{ij}$  is a function of the temperature. When comparing different solutes in the same solvent, the larger the Henry's constant the lower the solubility of the solute.

The activity coefficient accounts for the effect of concentration on the activity of the component in the liquid phase. The infinite dilution definition of the activity coefficient is used here; its significance is that at infinite dilution, the activity coefficient defined this way is unity.

The exponential term is the Poynting correction. It accounts for the effect of pressure on the reference fugacity, and it is important (significantly different from unity) only at high pressure. For a small molecule such as methane, hydrogen sulphide or carbon dioxide in water, the partial molar volume at infinite dilution is approximately 0.032 m<sup>3</sup>/kmol. Thus, at 7000 kPa and 20°C (293°K), the Poynting correction for these systems is about 1.1. Neglecting the Poynting effect

altogether at these conditions means the solubility is under predicted by approximately 10%.

A common definition used in describing the solubility of a gas in a liquid is partial pressure. The partial pressure,  $P_i$ , of a component in a gas mixture is defined as:

$$P_i = y_i P \quad (2)$$

The non-idealities in the vapour phase are embodied in the fugacity coefficient. As an approximation, the fugacity is to the partial pressure as the compressibility factor is to the molar volume. Included in this quantity is the effect of pressure, temperature and composition on the gas phase non-ideality. For an ideal gas mixture, the fugacity coefficient of all components,  $i$ , in the mixture is unity:

$$\phi_i^v = 1 \quad (3)$$

However, for a non-ideal mixture, this quantity can be less than, greater than or equal to unity. At relatively low pressure, it is generally less than unity and it can be as small as 0.1 (and even smaller for liquids). At high pressure and high temperature, the fugacity coefficient can be greater than unity; however,

it is rarely greater than two. Therefore, it is very important to include this contribution in the solubility model.

The fugacity coefficient in the vapour phase can be calculated using an equation of state such as the Soave-Redlich-Kwong (SRK) or Peng-Robinson (PR) equations. These cubic equations of state have been used for many years for modelling the fluid properties and phase equilibrium in petroleum systems containing light hydrocarbons and a few associated non-hydrocarbons such as carbon dioxide, hydrogen sulphide and nitrogen. However, they are less successful with water and other polar substances such as alcohols and glycols. Typically, the equations of state must be modified to predict accurately the pure component properties, and the mixing rules must account for the complex interactions.

At low pressure, both the Poynting correction and the fugacity coefficients are approximately unity. Furthermore, if the solubility is low, Equation 1 reduces to the more familiar form of Henry's Law:

$$x_i H_{ij} = y_i P \quad (4)$$

or equivalently:

$$x_i H_{ij} = P_i \quad (5)$$

Physically, this equation says that the solubility of a gas increases directly as the partial pressure of the component in the gas increases. However, this idealised version is limited to about 200–300 kPa and gases with solubilities less than about 0.1 mol%.

The ProTreat simulation tool's dehydration model uses the Peng-Robinson equation of state (EOS) for the vapour phase and currently offers a four-suffix Margules equation activity coefficient model based on the data of Bestani & Shing<sup>1</sup> for the liquid phase, as reported by Clinton *et al.*<sup>4</sup> A similar model based on the less conservative data of Parrish *et al.*<sup>6</sup> is planned for a future release.

There are two important aspects to thermodynamic modelling of

phase equilibrium in glycol dehydration systems: the water content of the treated gas; and the hydrocarbon, acid gas and especially the benzene, toluene, ethylbenzene and xylene (BTEX) content of the water-laden glycol. Table 1 compares ProTreat model results with *Gas Processors Suppliers Association (GPSA) Data Book* entries for saturated water content. Generally, ProTreat reproduces measured values of water content to within the accuracy of the data. The Peng-Robinson EOS that performs these saturated water content calculations applies a large number of interaction parameters ( $k_{ij}$ ) for the interactions between water and the various gases, as well as between the gases themselves.

Other components whose solubility in TEG is pertinent are the acid gases and hydrocarbons, especially the BTEX components. Vapour-liquid equilibrium constants (K-values) for BTEX and o-xylene are available in GPA RR-131, and the data there have been used to fit the ProTreat solubility model for these species. The data indicate that at typical contactor conditions, approximately 10–30% of the aromatics in the gas stream may be

Water content vs tray count	
Number of trays	Water lb/MMscf
5	8.5
6	6.7
7	5.7
8	5.1

Table 2

absorbed in the TEG solution. ProTreat results conform closely to the conclusions of RR-131 as they should, because ProTreat's solubility model has been regressed to the actual measured BTEX solubilities.

### Process simulation

The *GPSA Data Book* contains a nice example of dehydration with TEG (Example 20-11). The gas is water saturated at 600 psia, with other particulars noted in Figure 1. Two cases are detailed, both requiring two theoretical stages. One uses bubble cap trays, which, at a tray efficiency of 25–30%, translates into 6–8 actual trays. The other case uses 10ft of an unspecified structured packing. ProTreat has provision for a separate Stahl column, shown immediately below the stripper in Figure 1, but the stripper can also

be simulated without this column if desired. Two condenser outlet streams permit the withdrawal of wet stripping gas and/or water vapour from the system (Stream 19) and the removal of a specifiable portion of condensed water (Stream 20), with the remainder returned as reflux.

Table 2 shows the effect of the actual tray count on the water content of the dehydrated gas. ProTreat simulation indicates six trays are adequate to reduce the water content from 88.7 lb/MMscf to the target level of <7 lb/MMscf (32°F dew point). Tower diameter for 70% flood is 3ft. These values are in line with *GPSA Data Book* results. In summary, the available data indicate that the model is accurately reflecting literature data on the vapour-liquid equilibrium (VLE) and general TEG dehydration experience, as reported by GPSA.

### Dehydration column performance

Until now, only an equilibrium-stage model has been available for calculations involving the performance of structured packing. However, the HETP of the particular packing is surely related to

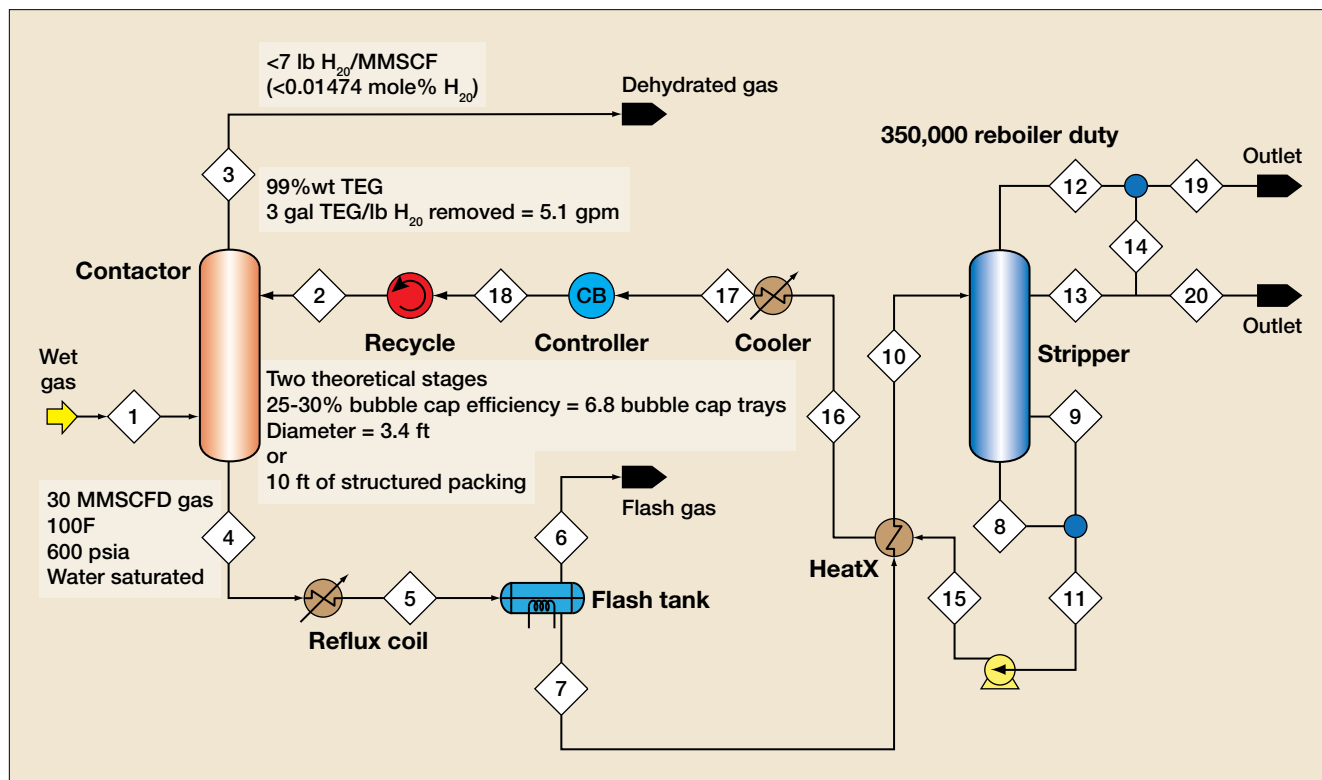

Figure 1 *GPSA Data Book* example 20-11

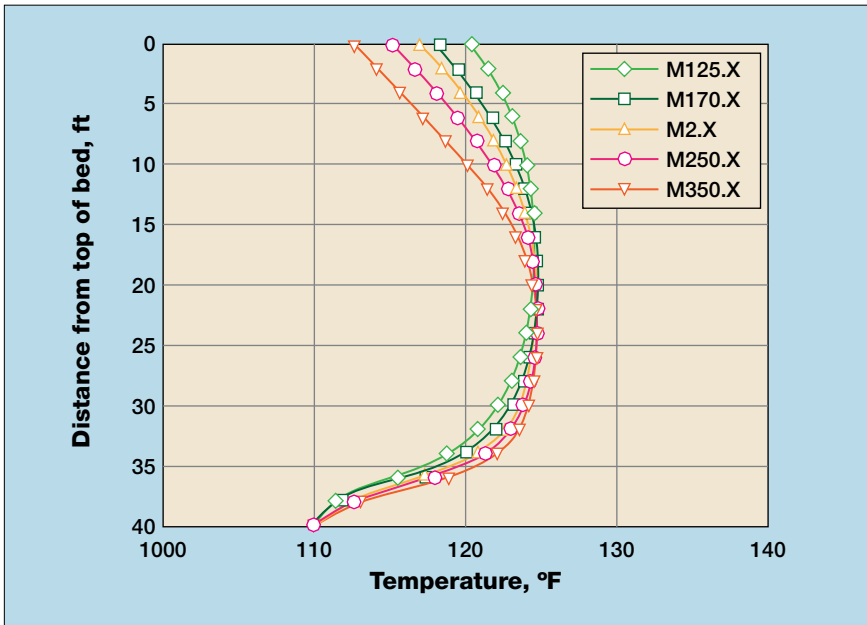

Figure 2 Temperature profiles and the effect of packing size in the Mellapak X Series

packing size. For structured packing, size can be expressed in terms of specific surface area and crimp size, characteristics that are geometrically related. Under otherwise identical process conditions, one should expect that large crimp packing will require a deeper bed to give the same performance as a relatively short bed of small crimp packing simply if for no other reason than because the surface area of the small crimp material is so much larger.

Figures 2 and 3 are simulations of how packing size within the Mellapak X Series (roughly 60-

degree crimp angle) packings affects dehydration performance. For Sulzer Mellapak structured packings, the packing designation (eg, M250.X) is a close indicator of the specific area, in this case 250 m<sup>2</sup>/m<sup>3</sup>. Simulations were all run with 40ft of packing and the absorber was sized for 70% flood (9–11ft diameter depending on crimp size). The absorber was set up to dehydrate 49 000 lbmol/h of wet sweet methane (trace CO<sub>2</sub> and H<sub>2</sub>S) using 250 gpm of 99.95 wt% TEG.

The gas-phase temperature profiles for the various packing

sizes shown in Figure 2 indicate that there can be a significant temperature bulge in dehydration columns caused by the phase change (condensation) of the water being absorbed. Water absorption generates sensible heating equivalent to its latent heat of condensation. Also, when small-crimp packings are used, the temperature bulge is closer to the bottom of the column because the larger surface area allows water to absorb so much faster. Figure 3 shows the water content of the gas at various positions along the height of the column. It is evident that, after traversing the bottom 20ft of M350.X packing, the gas is about as dry as 99.95 wt% TEG at 100°F can get it. With M125.X packing, on the other hand, water is still being removed even after the gas has passed through 40ft of packing. So the required bed height is very much a function of the packing size. It is not that rules of thumb cannot be made to work; rather, it is that the right rules of thumb, at least for packing, depend on too many parameters (not just packing type and size but also on the gas and solvent fluxes through the column) and this makes them rough at best and unreliable at worst. Until now, the answer to this dilemma has been to over-build the columns; however, in a competitive environment, surely being able to avoid over-design gives the knowledgeable contractor and the astute internals vendor a commercial advantage. Mass and heat transfer rate-based simulation is the precision tool that allows this to be done.

Figure 4 shows that the blanket rule of thumb of 6–8 trays for dehydration can be a gross oversimplification. The number of trays depends at least on the dryness to be achieved; that is, the dryness of the solvent. If the target dew point is not too stringent (say, 10 or 20lb H<sub>2</sub>O/MMscf), 6 or 8 trays seem adequate. But in very low dew point applications, such as LNG plants, two or three times that number of trays may be required to get to the desired dryness. With 99.97% TEG, for example, it is

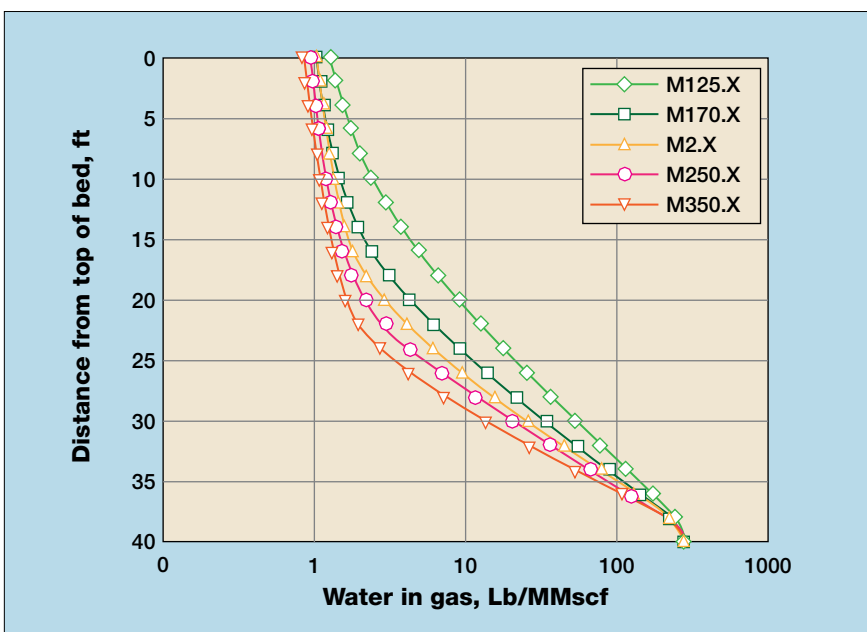

Figure 3 How water removal depends on packing size and packed bed depth

possible to get to below 1 lb/MMscf water content, but even after 16 trays, water is still being removed.

For the particular conditions simulated in this study, it should be mentioned that high TEG viscosity is a consideration and will negatively affect internals performance compared with light hydrocarbons, for example. At the solvent moisture levels encountered in these simulations, viscosity is not significantly affected by water content, and at the lowest temperature (feed solvent at 100°F) the viscosity is about 19 cP (for reference, corn syrup is 50–100 cP). This does not necessarily rule out using trays, although it does tend to make structured packing more attractive.

### Stahl columns and stripping gas

A Stahl column gives an extra stage of regeneration by taking the solvent from the reboiler and contacting it with a flow of dry inert gas. Stahl columns are essential when the dried gas must have a very low dew point. Figure 5 shows the effect of stripping gas rate (SCF per gallon of TEG solvent) on the TEG purity and on the water content of the treated gas for Example 20-11 from the *GPSA Data Book* scaled up by a factor of five and using six bubble cap trays in the absorber and a 10ft bed of FlexiPac 1.6Y in the regenerator (includes a 2ft reflux wash section). In terms of scale, the absorber is nearly 7ft in diameter and is drying gas that is water saturated at 600 psia and 100°F. The regenerator is only 15in in diameter.

The simulation results in Figure 5 show that using even a modest flow of stripping gas can reduce the water content in the treated gas by more than a factor of two. Stripping gas permits more water removal from the solvent and increases the dry TEG from 98.8 wt% to 99.8 wt%. This particular treated gas is dry enough by transmission line standards, but it is a long way from dry enough for an LNG plant, for example. However, this demonstrates the principle that a Stahl column can serve a useful purpose — it should be used when treated gas needs to be drier than usual.

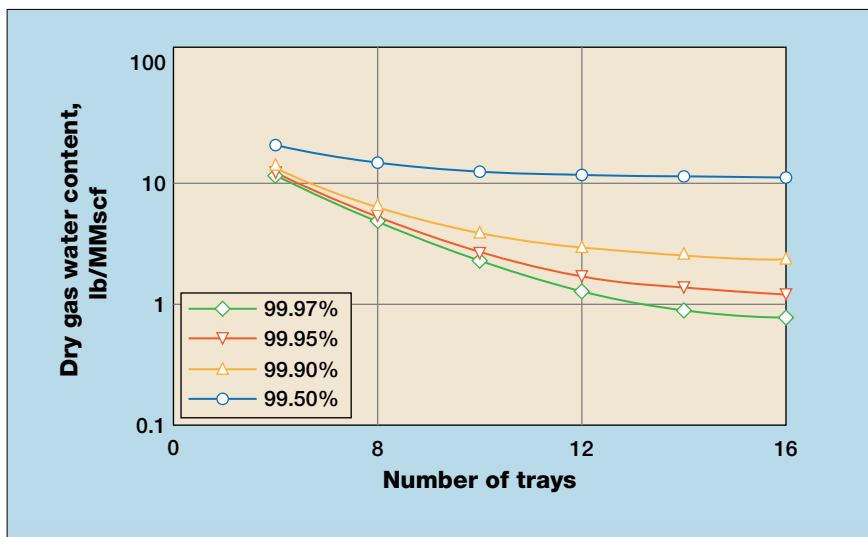

Figure 4 Water removal to low dew points requires deeper beds and more trays

### Observations from a mass transfer rate model

The mass and heat transfer rate model uses real trays, both in number and mechanical detail, and real packing in terms of actual bed depths of a specific packing with defined geometry, including crimp angle, crimp size, surface treatment, specific surface area and vendor. The simulation of a packed column begins by finely segmenting the packed height into a large number of thin cross-sectional slices to approximate the continuous nature of contacting in packing. As a result, one gets to observe mass and heat transfer effects on a fairly detailed scale.

Figure 6 shows the vapour and liquid temperature profiles through a 10ft-deep bed of 2in metal Nutter Rings in a regenerator operating at

1 psig. The dehydrator is treating 440 MMscfd of wet, sweet gas with a TEG flow of 1000 gpm, and the bone-dry nitrogen stripping gas flow to the Stahl column is 1.9 scf/gal. The bed starts with a 2ft-deep wash section for TEG recovery followed by an 8ft-deep stripping section for water removal. The stripper was simulated by dividing it into 40 segments, each having a 3in depth. Finer segmentation is, of course, possible, but it adds nothing to the detail and very little more to the accuracy of the simulation. We will traverse the regeneration column, starting with the condensate (essentially pure water), which enters the column from the condenser at 180°F and is heated by the gas stream (stripping gas and water), which is at 198°F.

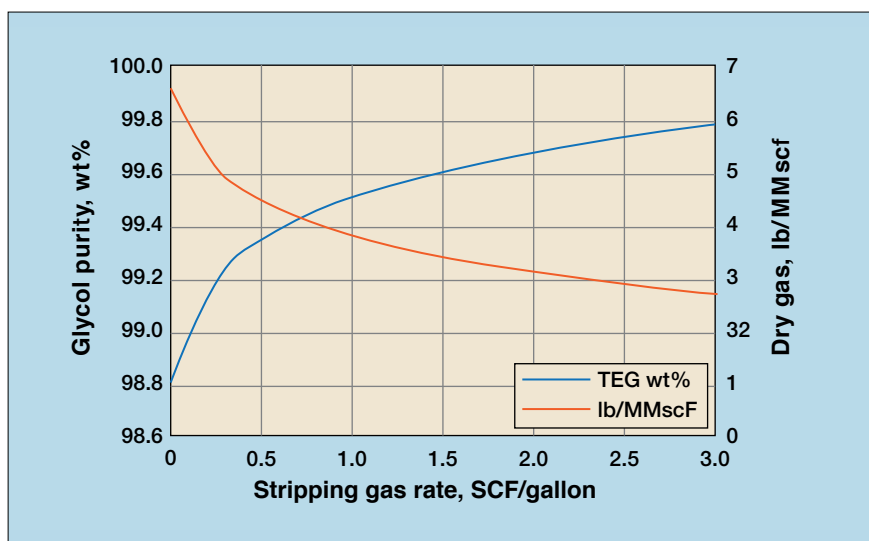

Figure 5 Effect of stripping gas flow on solvent dryness and water content of gas

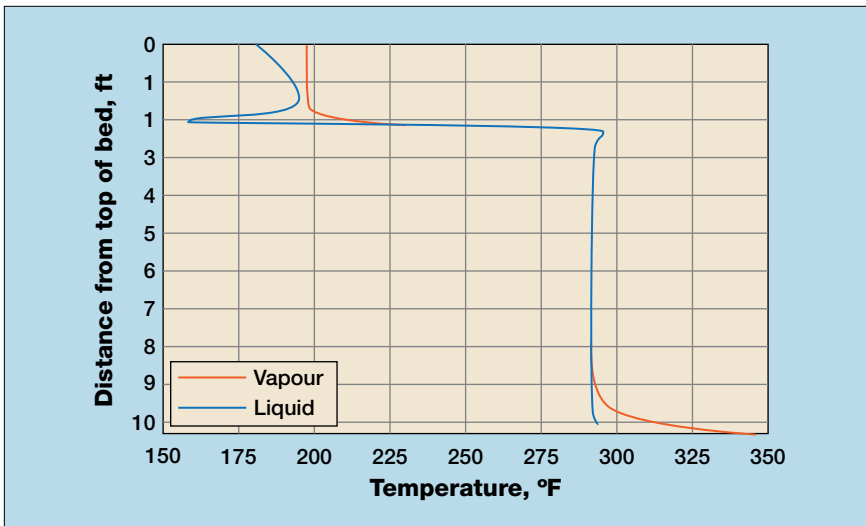

Figure 6 Temperature profiles in regenerator with stripping gas via Stahl column

As the condensate trickles down through the bed, it continues to be heated by the wet stripping gas, but within the first 18in its temperature reaches a peak (194.5°F) and then suddenly plummets to about 160°F. The gas becomes hotter as we descend through the column, and eventually it experiences a rapid climb to 294°F. The question is: why do the phase temperatures trend

this way? The answer for the gas phase is relatively simple: feed, preheated to 300°F, enters the column at the 2ft level and flashes into its vapour and liquid parts. The fact that the vapour temperature changes radically at the feed point is simply the result of the hot feed meeting a cold reflux water stream. But why does the reflux water cool so much?

When the vapour leaves the top of the stripping section, its water content is very nearly in equilibrium with the liquid in the stripping section. The liquid there is better than 95 wt% TEG with only 5 wt% (17–18 mol%) water. So, although saturated with water, it is saturated with only an 18 mol% water phase. When it hits the first reflux segment, this vapour is suddenly exposed to a pure, hot water stream (flowing from the wash section), so it is seriously under saturated against pure water. The consequence then is for water to evaporate as fast as possible so as to resaturate the hot gas, now against pure hot water. This is a typical humidification operation and has some interesting characteristics. The evaporation process is not mass transfer rate limited. Rather, it is limited by the rate at which the latent heat of vapourisation demanded by the humidification process can be drawn from the bulk liquid to the gas-liquid interface. This process is one of heat transfer and, indeed, the rate of humidification right above the feed point is controlled by essentially conductive heat transfer across the liquid film running over the packing. The process is heat transfer rate limited. The mass transfer driving force for humidification is so high that enough heat is drawn from the reflux water to cool it, in this case by approximately 33°F.

As we traverse lower into the column and approach the bottom of the stripping section, liquid starts to meet much hotter vapour coming from the reboiler. (The bubble point of TEG-water mixtures is quite sensitive to water content when the water content is low.) This cools the vapour and heats the liquid, and again some of the heat transfer is the result of water transferring from the vapour back into the liquid in the bottom couple of segments of the stripping section.

Figures 7a and b are intended to show how the use of stripping gas affects these temperature profiles. The plots are for the same 10ft bed of Flexipac 1.6Y structured packing referenced in Figure 5. Even when stripping gas is not used, the condensed water leaving the reflux

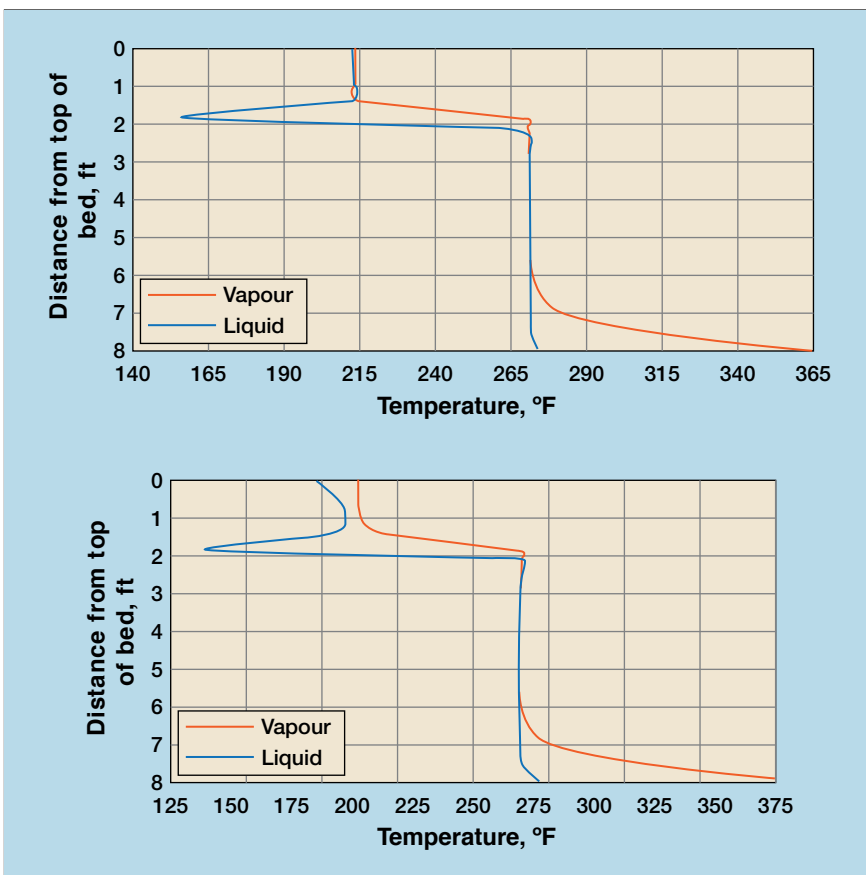

Figure 7 Stripping gas is not necessary for anomalous temperature profiles (a) No stripping gas (b) Stripping gas at 3 scf/gal

section meets a much hotter gas, and a good part of the temperature equilibration takes place by water evaporation from the reflux stream. This is, again, a humidification process and the reflux water cools as a result of the demand for latent heat for vapourisation. In Figure 7b, the presence of stripping vapour dilutes the gas leaving the stripping section, which results in slightly more driving force for humidification together with the small additional capacity of the gas for water. (How much the stripping gas adds to the driving force and capacity depends on the relative flows of stripping gas versus reboiler vapour.) Again, the reflux water temperature peaks and then drops from 197°F to about 141°F, for a total cooling of 56°F, the same as for the case without stripping gas. However, with stripping gas (dry nitrogen), the temperature bulge in the reflux section is a consequence of the dilution by nitrogen. We note in passing that, to maintain water balance, the no stripping gas case required a 212°F condenser temperature versus 180°F for the case with stripping gas.

#### Factors that affect dehydration of sweet gases

To learn more about the practical limits of glycol dehydration, a sensitivity analysis was conducted, starting with the 3 SCF/gallon stripping gas rate at 1.72 MMBtu/hr reboiler duty referenced in the preceding section. First, the reboiler duty was increased to 2.5 MMBtu/hr, which amounted to an increase from 1124 to 1634 Btu/gallon. This change allowed the glycol purity to increase from 99.79 to 99.96 wt% TEG. The water content of the dehydrated gas was predicted to drop from 2.7 to 2.0 lb/MMscf, assuming six bubble cap trays for contacting. This is not much of an improvement for nearly a 50% increase in reboiler energy. Are there enough absorber trays to take advantage of the greatly improved TEG dryness? The number of trays was increased from 6 to 8 in the glycol contactor, while maintaining the lean glycol purity of 99.96 wt%. This dropped the water content by

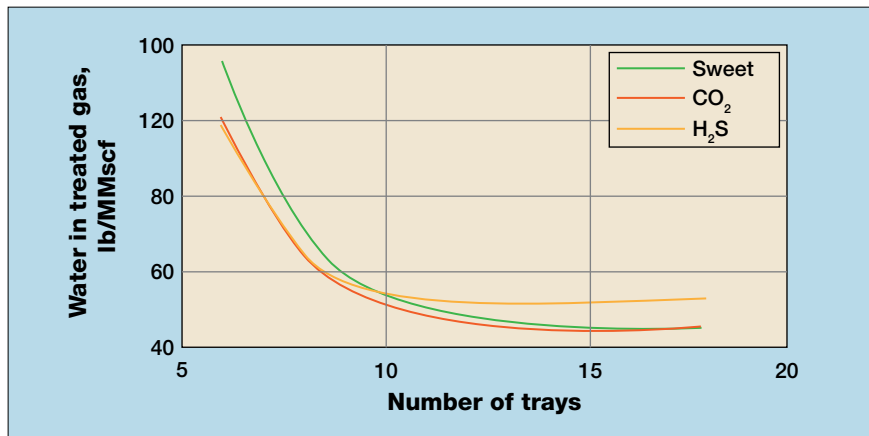

Figure 8 Effect of tray count on water content of methane, CO<sub>2</sub> and H<sub>2</sub>S dehydrated with 99.5 wt% TEG at 15 psig and 100°F using bubble trays

an order of magnitude, from 2.0 to 0.2 lb/MMscf. Twelve trays gave no improvement. So much for rules of thumb!

Finally, at 12 trays of dehydrator contacting, some of the reboiler duty was traded for stripping gas. Lowering the reboiler duty from 2.5 to 2.0 MMBtu/hr and doubling the stripping gas rate (from 3 to 6 SCF/gallon) resulted in a predicted water content of 0.13 lb/MMscf (a dew point well below the hydrate formation temperature). Simulated glycol purity was 99.975 wt%. So it appears that stripping gas is a more effective way to improve dehydration system performance.

There is much that can be learned by playing with a mass transfer rate model, even for such a seemingly mundane process as glycol dehydration. The mass and heat transfer rate model allows one to probe the limits of what is in practice

possible; for example, trading expensive reboiler duty for possibly cheaper stripping gas, or optimising dehydration unit performance in a demanding LNG setting. Since this kind of tool is so reflective of the real engineering physics, the real chemistry and the real processing happening in an amine, dimethyl ether of polyethyleneglycol (DMPEG) or glycol plant, using the tool as a virtual laboratory, pilot plant and full-scale virtual plant is very attractive.

#### Dehydration of nearly pure acid gases: H<sub>2</sub>S

Down-well disposal of acid gases (so-called acid gas injection) requires the gas to be compressed to a very high pressure. If the gas is wet, compressing it will cause liquid water to drop out and this liquid will be saturated with acid gas at high pressure. Unless one is

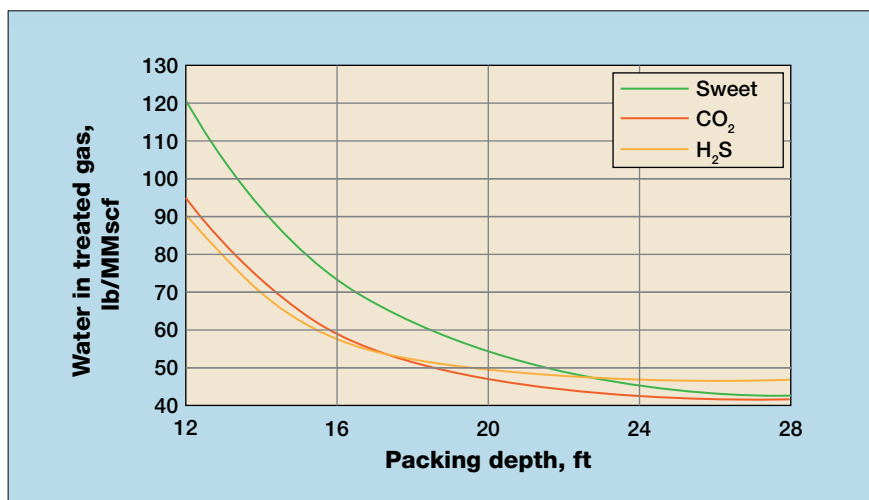

Figure 9 Effect of tray count on water content of methane, CO<sub>2</sub> and H<sub>2</sub>S dehydrated with 99.5 wt% TEG at 15 psig and 100°F using Mellapak M170.X structured packing

prepared to build compressors and other equipment from unobtainium, it is paramount that the water be removed from the gas before compression. Therefore, it is of interest to compare dehydration of otherwise pure but water-saturated H<sub>2</sub>S with the equivalent sweet gas volume. As Figure 8 shows, it is difficult to lower the water content to the same level as high-pressure pipeline gas, for example, simply because of the treating pressure. The lines in this plot are simulation results for bubble cap trays in a 10ft-diameter column treating 30 MMscfd of either pure methane, CO<sub>2</sub> or H<sub>2</sub>S saturated with water at 120°F. Lean solvent is 200 gpm of 99.5 wt% TEG at 100°F. Figure 9 shows similar results for Mellapak M 170.X structured packing.

Under otherwise identical conditions, the water content of H<sub>2</sub>S in equilibrium with the lean TEG is somewhat higher than it is for either CO<sub>2</sub> or even methane. This has to do with the very polar nature of H<sub>2</sub>S, which binds water more tightly to itself than CO<sub>2</sub> does. But this is information that can be gleaned more easily directly from VLE calculations. The mass transfer rate-based dehydration model, however, shows that in this instance H<sub>2</sub>S is pretty much completely dehydrated after about 12 trays (about 20ft of packing), whereas CO<sub>2</sub> and methane require 15 trays (24–26ft of packing) to reach their ultimate dryness.

In an overall sense, the acid gases appear to be no harder than hydrocarbons to dehydrate, although H<sub>2</sub>S is very polar, which leaves it a little wetter than most other gases. However, there is nothing particularly challenging about dehydrating the acid gases, except for their high solubility in the TEG solvent. For the conditions corresponding to Figures 8 and 9 (15 psig and 120°F), the methane, CO<sub>2</sub> and H<sub>2</sub>S content of the rich solvent is simulated to be 8.4 ppm, 0.66 mol% and 3.32 mol%, respectively. Thus, the water-laden solvent contains quite a bit of H<sub>2</sub>S and this must be removed before the solvent is regenerated to a suitable state of dryness, because it is a certainty that this much H<sub>2</sub>S

cannot be vented to atmosphere with the water vapour stripped from the solvent.

Its high solubility in TEG is really the main difficulty with dehydrating very high concentration H<sub>2</sub>S; otherwise, in terms of just water absorption, the acid gases are no more challenging than any other gas from a purely process standpoint. The difficulty is accurately representing the gas-phase non-idealities that arise from the highly polar nature of water and H<sub>2</sub>S.

### Conclusions

Rules of thumb are fraught with danger because often the rules simply do not apply. A blanket tray efficiency of 25% is close to the truth most of the time. But in deep water removal, 25% is optimistic

## The mass transfer rate-based tower model uses science and good sound engineering to predict performance

and, unless one adds several additional safety trays, failure will threaten. The situation with packing, be it random or structured, is much worse. Quoting or recommending a single HETP or HTU is foolhardy. The right value depends on the packing as well as on the operating conditions and the gas dryness sought. Rules of thumb had their place when the best one could do was an equilibrium-stage calculation, and reliance had to be placed on experience as expressed (and mis-expressed) in such rules of thumb. Today, we have available powerful heat and mass transfer rate-based simulation tools, and reliance on rules of thumb and other approximations and guestimates is no longer warranted.

The beauty of the heat and mass transfer rate-based approach to simulation is that one never has to worry about tray efficiencies,

artificial residence times, HETPs, HTUs and other rules of thumb. The mass transfer rate-based tower model does not use rules of thumb — it uses science and good sound engineering to predict performance. These results were all obtained without any correction factors whatsoever. They are true predictions in every sense of the word.

ProTreat is a mark of Optimized Gas Treating Inc.

### References

- 1 Bestani B, Shing K S, Infinite dilution activity coefficients of water in TEG, PEG, glycerol and their mixtures in the temperature range 50 to 140°C, *Fluid Phase Equilibria*, 50, 1989.
- 2 Carroll J J, What is Henry's Law?, *Chem. Eng. Prog.*, 87, 9, 1991, 48–52.
- 3 Carroll J J, Use Henry's Law for multicomponent mixtures, *Chem. Eng. Prog.*, 88, 8, 1992, 53–58.
- 4 Clinton P, Hubbard R A, Shah H, A review of TEG-water equilibrium data and its effect on the design of glycol dehydration units, Laurence Reid Gas Conditioning Conference, Norman, OK, 2008.
- 5 *Engineering Data Book*, Gas Processors Suppliers Association, 12th Ed, vol II, 20, 2004.
- 6 Parrish W R, Won K W, Baltatu M E, Phase behavior of the triethylene glycol-water system and dehydration/regeneration design for extremely low dew point requirements, 65th Annual Convention of the GPA, San Antonio, TX, 1986.

### John Carroll

**Nathan Hatcher** is Vice-President, Technology, Optimized Gas Treating, Buda, Texas. He has spent almost his entire career in amine treating and sulphur recovery, and has extensive experience in the practical application of process simulation to operations, troubleshooting and training. He holds a BS in chemical engineering from the University of Kansas and is currently a member of the Amine Best Practices Group. Email: nate.hatcher@ogtrt.com

**Ralph Weiland** is a co-founder of Optimized Gas Treating in Clarita, Oklahoma. He began working in gas treating in 1965 and taught chemical engineering for 30 years at universities in Canada, Australia and the US, and directed graduate research in gas treating. He holds BA Sc, MA Sc and PhD degrees in chemical engineering from the University of Toronto. Email: ralph.weiland@ogtrt.com