

# ACID GAS ENRICHMENT—MAXIMIZING SELECTIVITY

*Ralph H. Weiland*  
*Optimized Gas Treating, Inc.*  
*Clarita, OK*

## ABSTRACT

Acid gas enrichment (AGE) is a group of methods used to upgrade low quality off-gas from treating units to higher quality Claus plant feed or to a smaller volume stream suitable for reinjection. The process objective is to maximize CO<sub>2</sub> slip and minimize the H<sub>2</sub>S leak into vent gas from the system, thereby producing a gas enriched in H<sub>2</sub>S to the greatest extent possible.

The most common method to enrich is by using a *separate absorber* for treating the low-grade acid-gas stream coming from the regenerator. Because such streams contain very little else besides acid gases and water, virtually the entire sour gas stream can be very readily absorbed if presented with enough solvent. This makes this type of AGE unit a quite severe test of one's ability to model selectivity. Gas flow and composition vary rapidly through the contactor, and concentration profiles can become inverted, forming an H<sub>2</sub>S bubble within the contactor.

Another way to enrich the acid gas stream is simply to recycle a (substantial) part of the separated acid gas back into the feed to the contactor. This lets the absorber feed on an effectively richer sour gas and thereby produce a richer acid gas product stream. Almost nothing is free, however, and the cost may be higher solvent circulation and/or increased reboiler energy consumption.

This paper addresses the operation of AGE by examining in detail the effect of sour gas composition, solvent strength including amine partial acidification, operating temperatures, the type of internals (trays, type/size of random packing, type/size of structured packing), and the total quantity of internals (tray count, packed depths) on residual H<sub>2</sub>S leak and Claus feed or reinjection gas quality. Comparisons are made with new commercial plant operating data as well as with information presented at a previous Laurence Reid Gas Conditioning Conference.

## Introduction

The last 15 years have seen increased interest in acid gas enrichment (AGE) to provide higher H<sub>2</sub>S-content gas to Claus plants, and occasionally for down-well reinjection. The overwhelming majority of AGE plants have a dedicated enriching absorber. Today, the number of these plants operating globally is probably fewer than 25. There might have been more but several have failed to perform as expected and have been shut down, either because gas composition moved into an uneconomic operating region or expectations were unrealistic in the first place. Designing and operating AGE plants is a tricky business and requires a different mind-set from conventional high-pressure gas treating plants. Indeed, there is an operating window outside of which AGE is unlikely to give satisfactory results at all because high enough selectivity cannot be achieved in a single conventionally-operated column, or H<sub>2</sub>S leak is unacceptably high.

The general objective of AGE is the economic production of a high-quality Claus plant feed from one of lower quality. Process goals are (1) to reach the highest achievable CO<sub>2</sub> slip to produce maximum enrichment, and (2) to keep the H<sub>2</sub>S leak in the reject gas as low as possible so that the operation contributes minimally to the plant's total sulfur emission. In other words high selectivity, and concomitantly, very low H<sub>2</sub>S leak.

Designing and operating AGE plants is highly sensitive to a number of parameters, including lean solvent temperature (a serious constraint in the Middle East, for example), feed gas H<sub>2</sub>S to CO<sub>2</sub> ratio, choice of tower internals type, number of contact trays, and solvent selection. Indeed, just getting the tower internals right can play a decisive role in the success of an AGE application.

This paper addresses what performance expectations are reasonable for “conventional” AGE by examining in detail the effect of sour gas composition, level of solvent regeneration, solvent mix including amine partial acidification, operating temperatures, the type of internals (trays, type/size of random packing, type/size of structured packing), and the total quantity of internals (tray count, packed depths) on residual H<sub>2</sub>S leak and Claus feed or reinjection gas quality. Comparisons are made with new commercial plant operating data as well as with information presented at a previous Laurence Reid Gas Conditioning Conference. In addition, a rather clever recycle scheme is examined from the perspective of likely recycle ratios and regeneration energies needed for various improvements.

## Why Acid Gas Enrichment

In the context of sulfur recovery, the primary purpose of AGE is to present the SRU with a high H<sub>2</sub>S concentration acid gas feed. High H<sub>2</sub>S feed concentrations are beneficial to the SRU for several reasons and, additionally, they benefit the tail-gas cleanup unit (TGCU). Firstly, in the Claus furnace, the acid gas flame becomes unstable below about 45% H<sub>2</sub>S in the gas (Johnson et al., 1992). Even at concentrations below 55% H<sub>2</sub>S, controls become more complex, and below 35–45% complexities are even greater (Johnson and Wissbaum, 1998). The other side of the SRU coin is to keep the CO<sub>2</sub> concentration low in and of itself, so as to minimize the reaction of CO<sub>2</sub> with H<sub>2</sub>S to form COS in the reaction furnace. Eliminating CO<sub>2</sub> from the system hydraulically unloads the entire SRU/TGCU train. A third benefit is the virtual elimination of heavy hydrocarbons (HHCs) and BTEX components from the SRU feed because the AGE absorber will slip most of the HCCs and BTEX components that reach it in the acid gas from the primary treating plant. Unfortunately, COS and mercaptans are not very soluble or reactive in amines, especially the MDEA-based formulations needed for selective treating. Consequently, these trace sulfur species mainly slip through the AGE absorber and will contribute to the plant’s total sulfur emission. In addition, of course, the AGE cannot remove all the H<sub>2</sub>S—there will inevitably be a small H<sub>2</sub>S leak, a typical leak with MDEA being 100–200 ppmv. However, with certain specialty solvents or by using a stripping promoter such as a few 1000 ppmw phosphoric acid (0.1% to 2 wt% was reported by Kohl and Nielsen (1997) after Dibble (1985)), sulfate ion, or other so-called heat stable salt, an H<sub>2</sub>S leak of less than 10 ppmv can be achieved in a properly designed treating plant.

If the acid gas to the SRU is already above 55% H<sub>2</sub>S, there is probably insufficient benefit in taking special pains to enrich it further, unless ammonia is also being processed in the sulfur plant, or the plant requires debottlenecking. But in plants treating well-head gas with a high CO<sub>2</sub>:H<sub>2</sub>S ratio, adequate CO<sub>2</sub> slip even using the most selective solvent cannot produce an SRU feed of sufficient quality. For example, a high pressure gas containing one or two percent CO<sub>2</sub> and a few 100s of ppmv H<sub>2</sub>S cannot be treated with amines to produce an acid gas stream with more than a few mol% H<sub>2</sub>S, hopelessly inadequate for a conventional Claus SRU. An acid gas containing 25% H<sub>2</sub>S *can* be processed in an SRU, albeit with some difficulty—a gas with only a few percent H<sub>2</sub>S cannot. So AGE is most beneficial when the H<sub>2</sub>S concentration is below perhaps 25% in the acid gas from the gas treating unit’s regenerator. Even in plants with a moderate CO<sub>2</sub>:H<sub>2</sub>S ratio of say 4:1, if the plant is nonselective (LNG for example), total removal of acid gas will produce an acid gas stream containing only 20% H<sub>2</sub>S. Again, AGE becomes an interesting possibility.

## General Considerations

AGE is all about selectivity. Obviously, the ideal or perfect process removes all the H<sub>2</sub>S and none of the CO<sub>2</sub> from the raw gas because then solvent regeneration produces an acid gas consisting

entirely of wet H<sub>2</sub>S—perfect selectivity. Detailed discussions of selectivity have been presented in many places including Anderson et al. (1992) and Weiland et al. (2003).

Because the raw gas feeding the AGE absorber is itself high in CO<sub>2</sub>, and the CO<sub>2</sub> content progressively increases as the gas traverses the tower, the partial pressure contribution to the driving force for CO<sub>2</sub> absorption is always high. Conversely, H<sub>2</sub>S concentration is already low in the raw gas (which is why enrichment is being done) and it gets lower still as the gas passes through the contactor, reaching (we hope) ppm levels at the top. Thus the partial-pressure driving force for H<sub>2</sub>S absorption is relatively low. The other part of the driving force for absorption is the partial pressures exerted by partially loaded solvents. As succinctly put by Johnson et al. (1992), in part quoting Astarita et al. (1983, 1986), “The equilibrium solubility of H<sub>2</sub>S in chemical solvents such as MDEA is not much higher than the solubility of CO<sub>2</sub>. Since chemical solvents do not have significant thermodynamic selectivity, they must rely on the difference in *rates of absorption* of H<sub>2</sub>S and CO<sub>2</sub> to obtain the desired process selectivity (emphasis added)”.

The differences in absorption rates are determined partly by phase equilibrium, partly by reaction kinetics, and partly by the hydraulic and mass transfer characteristics of the contacting equipment *vis à vis* the relative magnitudes of gas- and liquid-side mass transfer coefficients. None of these factors operates in isolation from the others—they are all equally important to determining the actual mass transfer rates occurring at each point in the contactor.

Kinetically, H<sub>2</sub>S absorption is accompanied by an instantaneous proton transfer reaction associated with H<sub>2</sub>S dissociation and amine protonation. On the other hand, CO<sub>2</sub> reacts at finite rates, and in the case of selective amines *very slowly indeed*, forming bicarbonate ion but no amine carbamate. *Their relative reaction rates are at opposite ends of the spectrum.*

As far as equipment is concerned, trays and packing (both random and structured) exhibit quite different hydraulics and, therefore, should be expected to have different mass transfer characteristics with respect to relative gas- and liquid-phase resistances. Because the main mass-transfer resistance to H<sub>2</sub>S absorption is in the gas phase while for CO<sub>2</sub> it is in the liquid phase, relative absorption rates are affected by the type and mechanical details of the contacting equipment itself. Suffice it to note that AGE is a process controlled by mass transfer rates, and only a true heat- and mass-transfer-rate based model stands any realistic chance of actually *predicting* performance.

The only amine-based solvents that make any sense in this application are ones that do not react with CO<sub>2</sub> to form carbamates. This means tertiary and sterically-hindered amines are the only contenders and, of these, MDEA (perhaps assisted by partial neutralization) and the hindered amines are the only realistic candidates in AGE applications. Because the hindered amines currently in commercial use<sup>1</sup> are all members of the FLEXSORB family and are proprietary to ExxonMobil Corporation, this paper focuses on generic MDEA, including phosphoric acid as a promoter.

Regenerated acid gas is usually available within a fairly narrow pressure and temperature range: between 5 and 20 psig and 100°F to 120°F. Components are limited to H<sub>2</sub>S, CO<sub>2</sub> and water with only trace amounts of other components such as heavy hydrocarbons, BTEX, and inerts. The H<sub>2</sub>S content ranges from a few mol% for only slightly sour well-head gases (hundreds of ppmv) to many tens of mol% when the well produces gas with a high H<sub>2</sub>S to CO<sub>2</sub> ratio. The rest of the feed to the AGE unit is CO<sub>2</sub> with enough water to saturate the gas at the temperature and pressure of the overhead condenser on the gas treating stripper. Trace amounts of contaminants have no effect on AGE unit performance, save for those that exhibit surface activity, and which are excluded from the scope of this paper.

We begin with two examples that illustrate typical AGE operations and quantify the ability of simulation using a mass and heat transfer rate model to predict performance. These examples naturally suggest process improvements and they raise many questions concerning what more optimal conditions might be, whether another choice of contactor internals could have yielded better results, and whether

---

<sup>1</sup> There is a wealth of data on the hindered amine 2-amino-2-methyl-1-propanol (AMP) but this chemical does not appear to have found commercial use.

generic MDEA could have been improved upon, to name a few. Apart from a final example, exploring other processing schemes and answering these questions occupies most of the remainder of the paper

## Some Process Configurations

In terms of process configuration, the AGE absorber is typically in the same amine circuit as the TGPU or SCOT unit because they make similar demands on solvent purity, both require a maximally selective solvent, and both are relatively low-pressure operations. The amine circuit for these units is usually separate from the main gas treating plant simply because the SCOT and AGE contactors make different demands on the amine than the primary high-pressure treating plant does. In fact, the main treating plant may use a different amine altogether.

### Stand-alone AGE

The first and most obvious processing scheme is a standalone AGE unit, perhaps utilizing a lean amine stream from the same regenerator as the TGPU. Figure 1 shows the simplest example. The gas being upgraded contains only 20% H<sub>2</sub>S, far from ideal for an SRU. The other conditions shown in the figure are a snapshot of operations on a particular day. There were insufficient data even to check an overall material balance, let alone component balances. The flowsheet was simulated using ProTreat™ with the reboiler duty adjusted to reproduce the regenerator's reported reflux flow. As is typical, useful operating data are extremely hard to come by for AGE units, probably because no one wants to handle

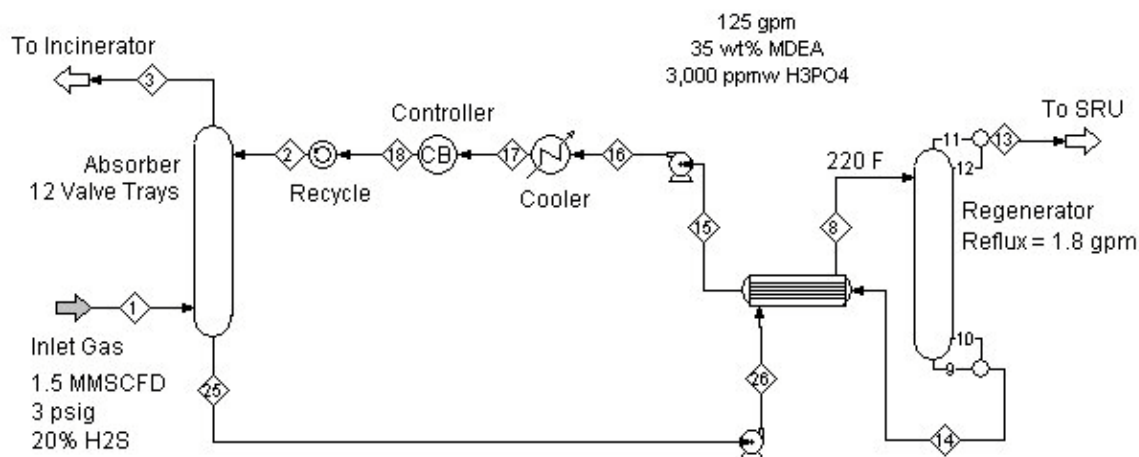

Figure 1 Simple Standalone AGE

gas samples having high H<sub>2</sub>S levels. In this particular case, no solvent sample analyses were available, nor was the H<sub>2</sub>S content of the SRU feed gas measured so the only measurement available was the treated gas H<sub>2</sub>S concentration, reported to be less than 100 ppmv. ProTreat simulation predicted a value of 43 ppmv in agreement with reported plant performance. Plant CO<sub>2</sub> slip was unknown; however, ProTreat predicted 85% slip which seems to be fairly typical for low pressure selective treating. The regenerator molar-reflux ratio was calculated to be very close to unity which, for achieving low residual H<sub>2</sub>S loading, is not particularly vigorous regeneration. Simulated residual loadings were 0.0008 and 0.001 for H<sub>2</sub>S and CO<sub>2</sub>, respectively. For a solvent using phosphoric acid as a stripping promoter, these are not especially low numbers. However, without the phosphoric acid promoter, predicted lean loadings

™ ProTreat is a trademark of Optimized gas Treating, Inc.

are 0.008 and 0.04 mol/mol, respectively, roughly a factor of between 10 and 40 times higher than with enhanced stripping. Furthermore, the treated gas H<sub>2</sub>S leak would have been nearly 200 ppmv.

### SCOT and AGE Units with Common Regenerator

The design and ultimate performance of an AGE unit depends on lean amine quality, something that can only be established if the SCOT unit is included as well. Figure 2 shows a PFD of SCOT and AGE units

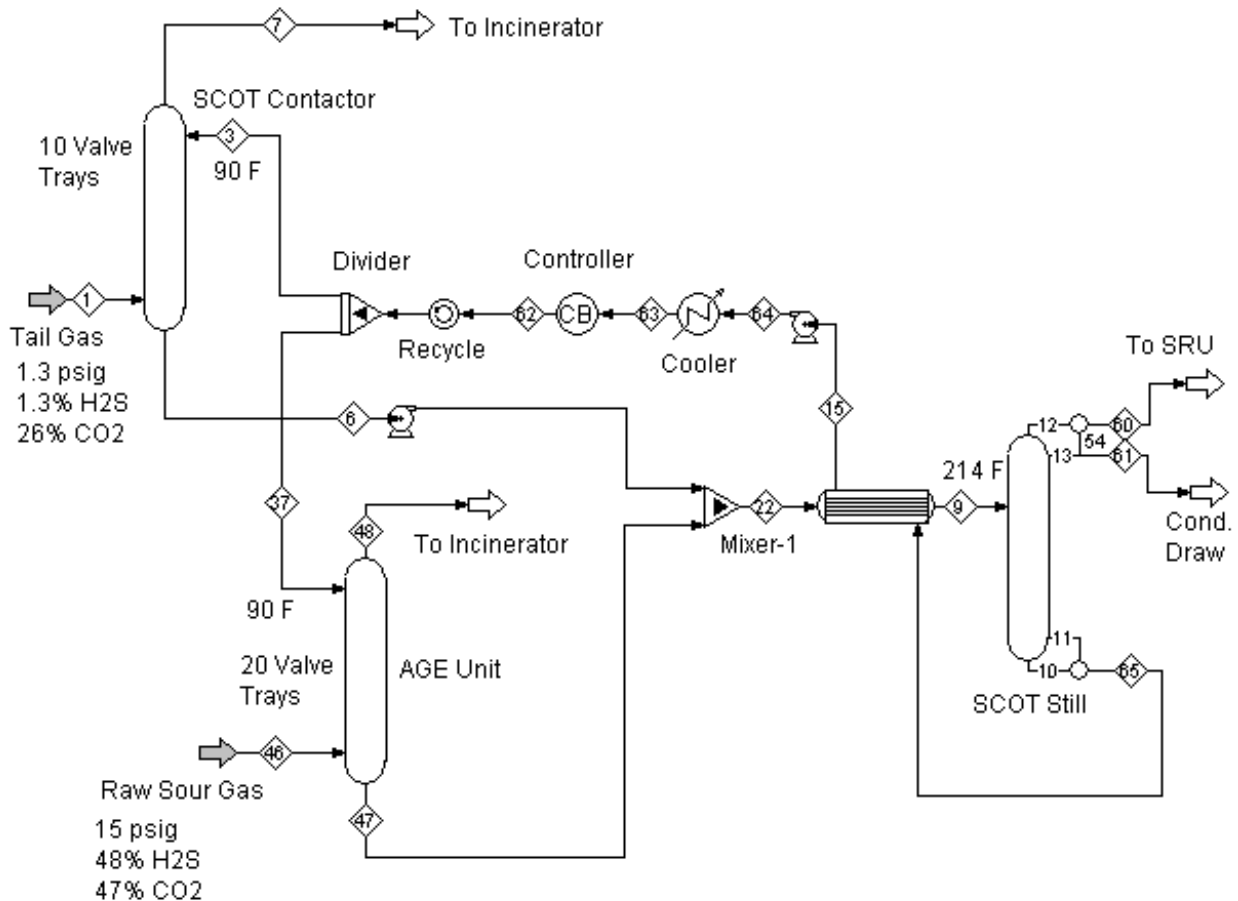

**Figure 2 AGE and SCOT Units with Common Regenerator**

combined in the simplest way possible—just connected through, and served by, a common regenerator. The data shown in the figure are for an existing plant. The sour gas to the AGE unit is already fairly rich in H<sub>2</sub>S; nevertheless, it is being further enriched because of the benefits to sulfur recovery. This plant is operating with 50 wt% generic MDEA. Again, data are scanty except to say that the SCOT unit is leaking several hundred ppmv and the AGE is treating down to around 100 ppmv. Both these figures were confirmed by ProTreat simulation which predicted 445 ppmv and 101 ppmv H<sub>2</sub>S leak from the SCOT and AGE units, respectively. No information was available on the gas stream to the SRU, although ProTreat predicted nearly 83% H<sub>2</sub>S on a dry basis with 96% and 83% CO<sub>2</sub> slip through the SCOT and AGE units, respectively. Simulation results for this and other scenarios are shown in Table 1.

The tail gas treater is the bigger contributor to sulfur emissions because of its high total flow rate and higher residual H<sub>2</sub>S content. Simulation showed the SCOT contactor to have close to the optimal number of trays; with too-few-trays providing too little contact to remove the maximum amount of H<sub>2</sub>S, and too many trays allowing too much CO<sub>2</sub> absorption, and using up too much solvent loading capacity.

The important finding from simulation, however, was that the SCOT contactor was *not* lean-end pinched. In other words, the solvent lean loadings was not setting the H<sub>2</sub>S leak; rather, the mass transfer rates themselves were.

**Table 1 Effect of Changes to Process Variables on Unit and Plant Performance (Constant Total Circulation Rate)**

	<b>1 Base (50% MDEA)</b>	<b>2 Base + H<sub>3</sub>PO<sub>4</sub></b>	<b>3 Base with 2x Amine to SCOT</b>	<b>4 Case 2 with 2x Amine to SCOT</b>	<b>5 Case 4 at 10% More Reboiler Duty</b>
SCOT Leak H <sub>2</sub> S (ppmv)	445	1,044	283	104	45
AGE Leak H <sub>2</sub> S (ppmv)	101	6	294	98	40
Lean Load H <sub>2</sub> S (m/m)	0.0047	0.00014	0.01	0.0012	0.0005
Lean Load CO <sub>2</sub> (m/m)	0.00013	0.000098	0.0002	0.00005	0.000038
SRU Feed (%H <sub>2</sub> S Dry)	82.9	75.7	82.0	82.7	82.7
Sulfur Emission (lb/hr)	4.41	9.96	3.21	1.16	0.51

The importance of the difference between lean-end pinching and mass transfer rate limitations became abundantly evident when a few thousand ppmw of H<sub>3</sub>PO<sub>4</sub> was added as a stripping promoter to the solvent in the simulation. Under otherwise identical conditions, and despite the additive reducing the lean solvent H<sub>2</sub>S loading from 0.0047 to 0.00014 mol/mol, the H<sub>2</sub>S leak from the SCOT absorber actually *deteriorated* from 445 ppmv to over 1,000 ppmv. The reason: the reduced lean loading is more than compensated by the increased H<sub>2</sub>S back-pressure at absorber temperatures, so H<sub>2</sub>S mass transfer (absorption) rates throughout the column fall. This is perhaps indicative of rich-end pinching. Turning to the AGE unit, however, the H<sub>2</sub>S leak from the AGE column was *improved* from 100 ppmv to 6 ppmv because the mass transfer rates are overshadowed by the fact that the AGE is completely lean end pinched with respect to H<sub>2</sub>S. In other words, the effect of reduced lean solvent loading of H<sub>2</sub>S has full impact at the lean end of the AGE absorber. The important lesson to be learned from this exercise is that *for a stripping additive to be fully effective, all the columns served by the common solvent must be designed and operated for lean-end pinch conditions.*

The problem with using an additive to reduce H<sub>2</sub>S leak in this case is that the additive causes a deterioration in SCOT column performance that exceeds its benefit to the AGE column. If the additive is to be made effective, the SCOT column therefore must be forced into a lean-end-pinched state. Undoubtedly this can be done in several ways—the one chosen here for illustration was to double (arbitrarily) the solvent flow to the SCOT absorber. This may seem radical; however, the AGE handles more than 15 times the H<sub>2</sub>S fed to the SCOT unit so doubling the smaller of two flows does not add tremendously to the total circulation rate through the plant. Column 3 of Table 1 shows just how little a doubling of the solvent flow to the SCOT column affects performance without additive, with all other conditions including reboiler energy fixed. However, the higher flow increases stripping effectiveness of the additive itself (Column 4). Solvent stripping is still not what it could be—Column 5 of Table 1 shows the effect of a 10% increase in reboiler duty; a further 10% lowers both H<sub>2</sub>S leaks by half again.

None of these cases is meant to represent optimal conditions—they are illustrative and are intended only to indicate directionality, and the sort of performance changes that result from corresponding changes in process parameters. Granted that the results in Table 1 are simulations; however, the extent to which the ProTreat simulations agree with the rather limited plant performance data lends comfort that they are probably fairly accurate across the board.

## DUAL SOLVE Process

Beyond using a common regenerator for the SCOT and AGE units, further improvements to the process configuration are possible. The rich solvent from the SCOT unit is always going to be fairly lightly loaded with the acid gases. Rather than sending it directly to regeneration, this lightly-loaded solvent might be better utilized by sending at least a portion of it to the AGE unit where it could be used for bulk removal of H<sub>2</sub>S in the lower part of the contactor, and would allow a smaller solvent stream to be sent to the top of the AGE for final gas cleanup. This would result in a reduction in solvent circulation rate and, therefore, a concomitant reduction in regenerator size and energy consumption, as well as smaller peripheral equipment such as pumps and heat exchangers. This scheme is referred to as the DUAL-SOLVE Process by Johnson et al. (1992), its key feature being the solvent cascade from the SCOT unit as shown in Figure 3.

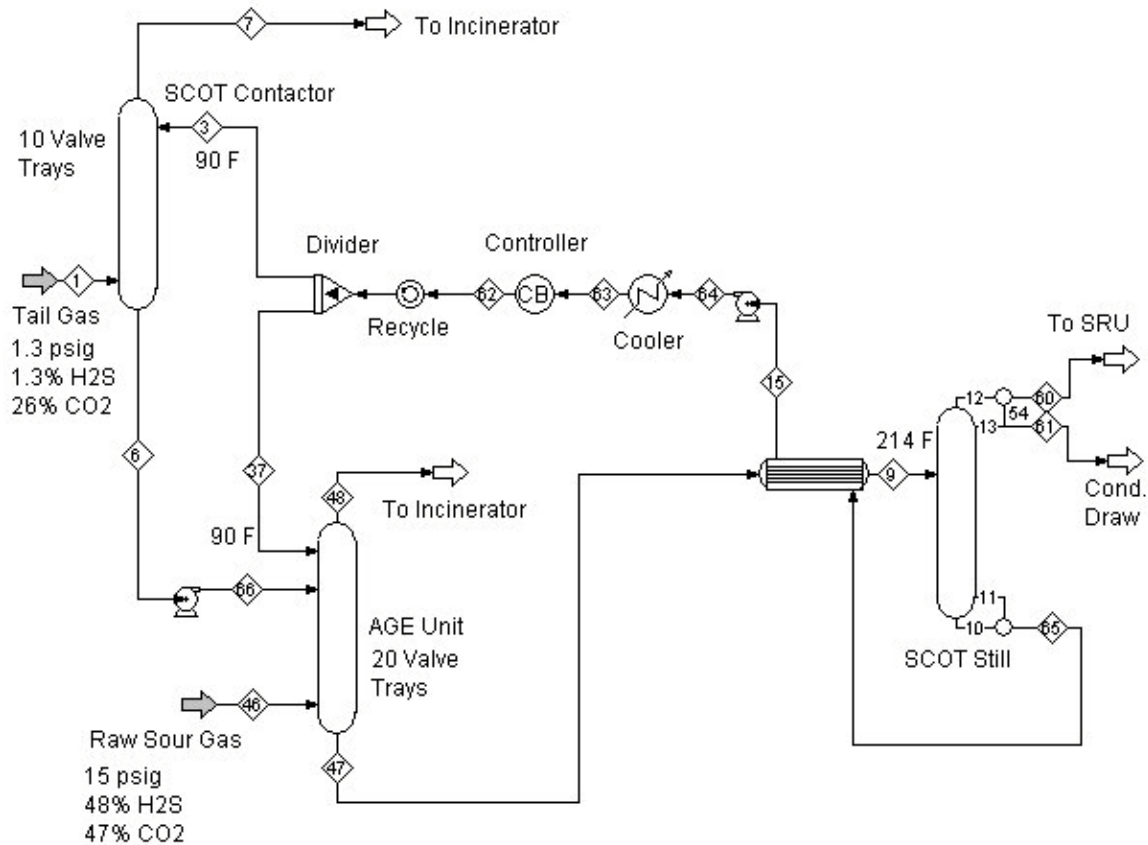

**Figure 3 DUAL-SOLVE Process**

The process parameters shown in Figures 2 and 3 were kept the same so that the effect of cascading could be scrutinized without masking effects from other parameters having been changed as well. For this example, the solvent flow to the SCOT unit was kept the same as in the original plant and any solvent flow reductions made possible by the cascading were taken by the AGE absorber. Because only 30% of the total solvent was used by the SCOT column, all of it was subsequently fed to the AGE unit on tray 14 from the top. ProTreat simulation showed that the total solvent circulation rate could be reduced by 20% and the reboiler heat duty by 10%, while maintaining exactly the same H<sub>2</sub>S leak values from both the SCOT and AGE units. The area of the cross exchanger could be reduced by nearly 40% and additional savings of course would be realized in other peripherals as well. But this is not the only scheme that yields benefits.

## Enriched Gas Recycle

The performance of the AGE unit is influenced by the composition of the gas being upgraded in the sense that the higher the H<sub>2</sub>S content of the raw gas, the greater the H<sub>2</sub>S content of the SRU feed that can be produced. In the case of Figure 3, for example, the gas to the AGE unit is already quite high in H<sub>2</sub>S and the SRU feed produced is even higher still. Therefore, no further process improvement is warranted in this case. However, for AGE feed gases of much lower quality, 8% H<sub>2</sub>S say, the scheme in Figure 3 is not the last word.

In the case of a low quality raw gas, if a portion of the gas produced from the AGE unit's regenerator were recycled back to the AGE contactor feed, the feed stream to the AGE would automatically be richer in H<sub>2</sub>S, and one might anticipate that an even richer SRU feed might result. One possible PFD for this scheme is shown in Figure 4. This may or may not require a higher solution rate or higher regenerator energy consumption, depending on specific conditions. The acid-gas-recycle approach may be what is referred to as a "special design feature" by Johnson and Wissbaum (1998) or the Super ENRICHMENT process by Johnson et al. (1992), although the literature does not really make this connection clearly. To illustrate the possible benefits of recycle, a lower quality sour gas, 8% H<sub>2</sub>S, is used for enrichment. The data shown in Figure 4 are simulated and compared with the same gases processed via DUAL-SOLVE alone. All flows, temperatures, pressures, heat duties and vessel internals were maintained exactly the same between the recycle and DUAL FLOW configurations and the percentage of SRU gross feed returned to the AGE column was varied from zero to 75% to see what effect recycle had on SRU feed quality as well as on the leak rates from the two absorbers. Results are shown in Table 2 and in Figures 5(a) and 5(b).

**Table 2 Effect of Recycle on Enrichment and H<sub>2</sub>S Leak from Absorbers**

<b>% Recycle</b>	<b>AGE H<sub>2</sub>S Leak (ppmv)</b>	<b>SCOT H<sub>2</sub>S Leak (ppmv)</b>	<b>% H<sub>2</sub>S in Dry SRU Feed</b>
0	63	268	40.1
20	76	289	45.4
40	90	313	52.4
60	109	346	62.5
70	138	368	70.7
75	5,400	379	76.2

By recycling about 70% of the enriched gas back to the front end of the AGE unit, the simulations as shown in Figure 5(a) predict that an almost two-fold improvement in SRU feed quality, from 40% H<sub>2</sub>S to 70% H<sub>2</sub>S can be enjoyed simply for the cost of providing a recycle line. There is no increase in either solvent rate or regenerator heat duty required in this case. But one comes hard up against a limit at around 71% recycle—H<sub>2</sub>S "breaks through" the AGE and the H<sub>2</sub>S leak begins to increase dramatically because the solvent rate is just not sufficient to absorb any more H<sub>2</sub>S. The contactor gradually goes from lean-end to rich-end pinched as the gas recycle (i.e., the H<sub>2</sub>S load) increases, until suddenly H<sub>2</sub>S breaks through. Undoubtedly more vigorous stripping or higher solvent rates could be used to achieve even greater enrichment. However, it is certainly clear that acid gas recycling can be a viable means of greatly enhancing SRU feed quality with only a minimal additional capital investment and no increase in operating costs.

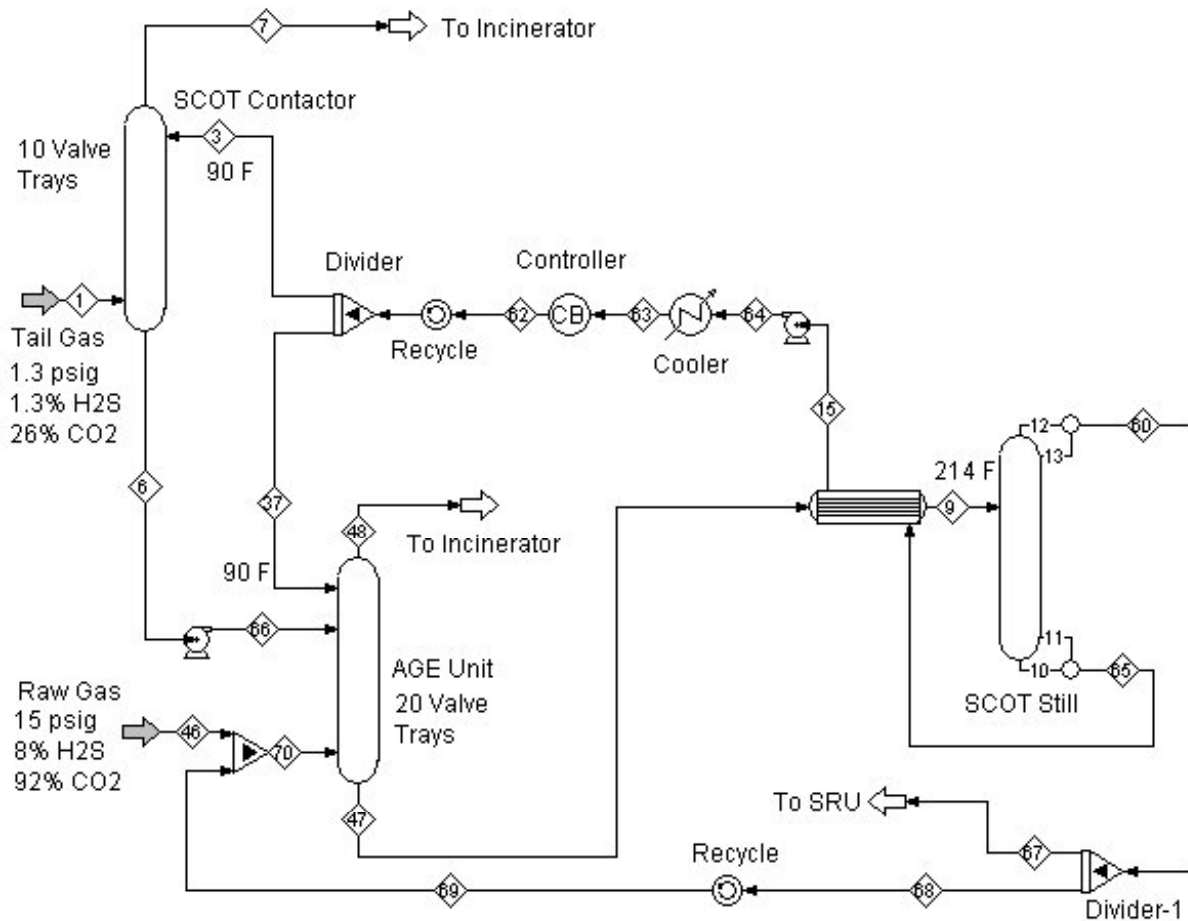
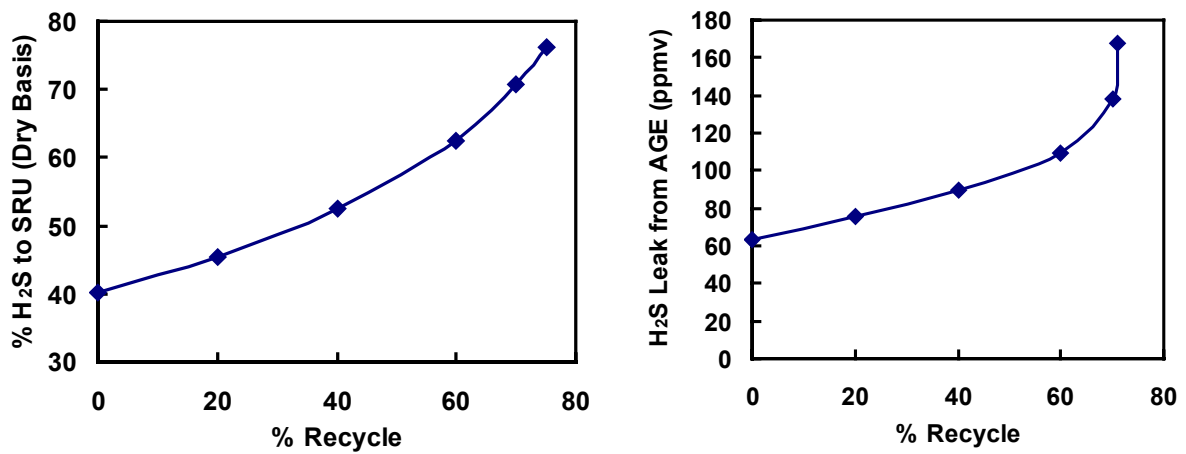

Figure 4 DUAL-SOLVE Process Combined with Acid Gas Recycle



(a) Enriched Gas Quality

(b) H<sub>2</sub>S Leak from AGE Unit

Figure 5 Effect of Enriched Gas Recycle on Key Performance Parameters

## Processing Conditions and Contactor Design

There are several questions that could be asked concerning the effect of such process conditions as operating pressures and temperatures, and types of tower internals on the performance of AGE contactors. Is higher pressure better than lower? Should the lean amine be warm or cool? Are trays superior to packing? How much packing and how many trays are best? And are there really general rules-of-thumb? To answer some of these questions, we will look at two extremes: Upgrading very low H<sub>2</sub>S content (3%) sour gases and enriching already high H<sub>2</sub>S gases (30%) further using generic MDEA in a stand-alone absorber are considered.

### Low H<sub>2</sub>S Gas

The base case is a 12-tray contactor with 1-pass valve trays and 2.5-in weirs enriching 3 MMscfd of 3% H<sub>2</sub>S, 97% CO<sub>2</sub> gas at 3 psig and 120°F. The solvent is 100 USgpm of 35 wt% MDEA at 85°F. The regenerator takes 220°F rich amine and processes it across 22 valve trays also with 2.5-in weirs and using a reboiler duty of 6 MMBtu/hr. For this base case, these conditions correspond to a molar stripping ratio<sup>2</sup> of 4. Simulation gives a 4.7 ppmv H<sub>2</sub>S leak and 91% CO<sub>2</sub> slip for the base case and a regenerator off-gas containing 25.9 mol% H<sub>2</sub>S. This is not a particularly wonderful SRU feed and it probably would benefit from acid gas recycle, although to what extent and at what cost is another story for another time—the purpose of this example is to assess sensitivity to changes in process conditions and alternative tower internals. For the discussion, only a single parameter at a time is varied from this base case. The effect of varying parameters away from the base case is shown in Table 3.

Increasing the contactor pressure slightly improves H<sub>2</sub>S removal, but at the expense of reduced CO<sub>2</sub> slip and, therefore, a leaner SRU feed gas. There are no surprises from raising and lowering the total tray count: more trays mean better H<sub>2</sub>S removal and poorer CO<sub>2</sub> slip and SRU feed quality. However, reducing tray count can substantially improve the enrichment. The performance of the random and structured packings selected for comparison, however, is somewhat different from trays, although the differences are not radical ones. Assuming that 12 trays on 2-ft spacing can be replaced by 24-ft of packing, still with enough head room for a distributor, the most direct comparisons are between the cases highlighted in bold in the table. The simulation suggests that conventional valve trays in this particular configuration give a few percentage points more CO<sub>2</sub> slip than does packing and, therefore, produce a somewhat richer SRU feed. From a purely mass transfer standpoint, trays are preferred; however, packings offer small tower diameters (usually not very important at these low pressures) and greatly reduced pressure drops over trays. What emerged from further simulation work was that if packing of any kind is to be used, it should be large crimp or large diameter; otherwise, selectivity and SRU feed quality will suffer. The caveat is that the packing must not be *too* big; for example, in this case using 3-inch Raschig rings gave a predicted H<sub>2</sub>S leak of 25 ppmv. The reason is probably the specific surface area of such large rings—68 m<sup>2</sup>/m<sup>3</sup> versus 88 m<sup>2</sup>/m<sup>3</sup> for IMTP-50. The optimal tray or packing type and size is obviously quite specific to each application.<sup>3</sup>

There is anecdotal evidence that AGE is less successful in locations such as the Middle East where ambient (and therefore coolant) temperatures are high, so the effect of the lean amine temperature on performance is worth considering. The simulated effect on the H<sub>2</sub>S leak *rate* is shown semi-logarithmically in Figure 6. In the simulations, all parameters were held constant, including

---

<sup>2</sup> Stripping ratio is the ratio of moles water to moles total acid gas in the overhead vapor from the still column.

<sup>3</sup> An interesting aside is to wonder whether trays with large valves might not perform better than ones with small openings, since it is known that froth coarseness (hence interfacial area) is related to valve size. This would provide less contact area per tray and therefore it might favor CO<sub>2</sub> slip.

component flows to the AGE contactor, and the temperature of the raw gas was made equal to the lean amine. Over the temperature range from 65°F to 115°F the H<sub>2</sub>S leak rate is predicted to rise twenty fold from 0.0008 to 0.018 lbmol/hr. The corresponding H<sub>2</sub>S concentration range is 3 to 55 ppmv. H<sub>2</sub>S leak is highly sensitive to treating temperature, although in this case where the raw gas is dilute in H<sub>2</sub>S, leak is predicted to be always less than 100 ppmv.

**Table 3 Effect of Varying Contactor Away from Base Case — Low H<sub>2</sub>S Feed**

Contactor Condition	H <sub>2</sub> S Leak (ppmv)	CO <sub>2</sub> Slip (%)	%H <sub>2</sub> S in SRU Feed
<b>Base Case (12 trays)</b>	<b>6</b>	<b>91</b>	<b>26</b>
Pressure = 15 psig	2	86	18
20 trays	1	87	19
15 trays	2	90	23
10 trays	16	92	28
8 trays	61	94	33
7 trays	126	95	36
6 trays	270	95	39
Lean @ 100°F	11	92	28
<b>24 ft IMTP 50<sup>(a)</sup></b>	<b>2</b>	<b>85</b>	<b>17</b>
18 ft	7	89	21
12 ft	77	93	29
<b>24 ft ISP 5TX<sup>(b)</sup></b>	<b>3</b>	<b>84</b>	<b>16</b>
18 ft	10	87	20
12 ft	80	91	26

(a) IMTP 50 is a random packing of roughly 2-inch nominal size, area = 98 m<sup>2</sup>/m<sup>3</sup>

(b) ISP (Intalox Structured Packing) 5TX is large crimp, 60° crimp angle, area = 88 m<sup>2</sup>/m<sup>3</sup>

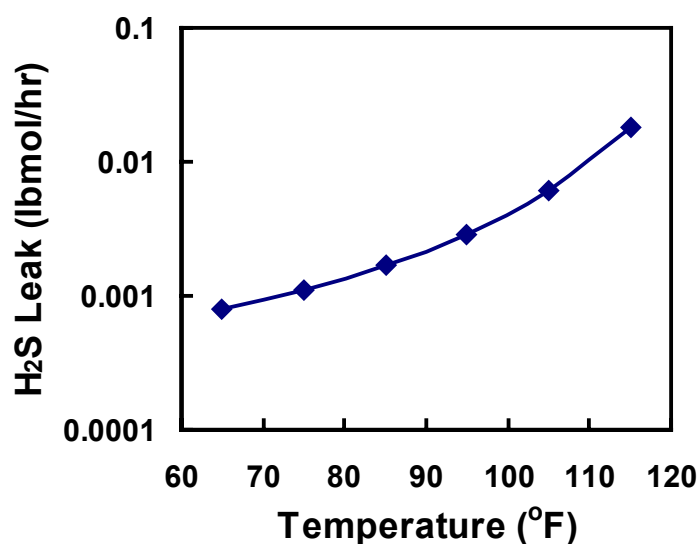

**Figure 6 Effect of Treating Temperature on H<sub>2</sub>S Leak Rate for a Low H<sub>2</sub>S Raw Gas**

## High H<sub>2</sub>S Gas

In the Base Case operation here, the feed gas contains 25 mol% H<sub>2</sub>S and is treated with 150 USgpm of 50 wt% MDEA. Otherwise, all other conditions are identical to the Low H<sub>2</sub>S case. Table 4 shows the sensitivity to various parameters.

For this higher H<sub>2</sub>S feed, simulation suggests that when the tray count itself is fairly small (but roughly how most people would expect an AGE contactor to be built), removing a single tray (13 to 12) can double the H<sub>2</sub>S leak while providing only a very modest gain in SRU feed gas quality. Increasing solvent circulation to hold the H<sub>2</sub>S leak constant may wipe away the gain of fewer trays. This kind of sensitivity is not seen with the low H<sub>2</sub>S feed because the original raw gas contains so little H<sub>2</sub>S in the first place. Replacing the trayed volume of the absorber with an equal quantity of random or structured packing produces lower simulated H<sub>2</sub>S leak, but poorer quality SRU feed because this much packing absorbs more CO<sub>2</sub>—only slightly more in the case of IMTP 50 but quite a bit more with the structured packing ISP 5TX. The trays, IMTP and ISP internals are hydraulically at 82%, 52% and 40% of flood, respectively in this column.

Figure 7 shows the effect of the AGE unit's operating temperature on H<sub>2</sub>S slip; both slip rate and H<sub>2</sub>S concentration in the treated gas going to the incinerator are shown. Note the log scale on the leak-rate and %Leak axes. When the raw gas is already fairly high in H<sub>2</sub>S, the effect of contactor temperature on leak is much more pronounced. Over the temperature range from 65°F to 115°F the leak rate increases by a factor of 500 as does the leak measured in ppmv. Thus, referring to Figures 6 and 7, significant enrichment with manageable H<sub>2</sub>S leak is not too strenuous when the feed gas is fairly dilute. However, to enrich 25% H<sub>2</sub>S raw gas at high contactor temperatures may be well-nigh impossible, at least using a simple, straightforward process strategy.

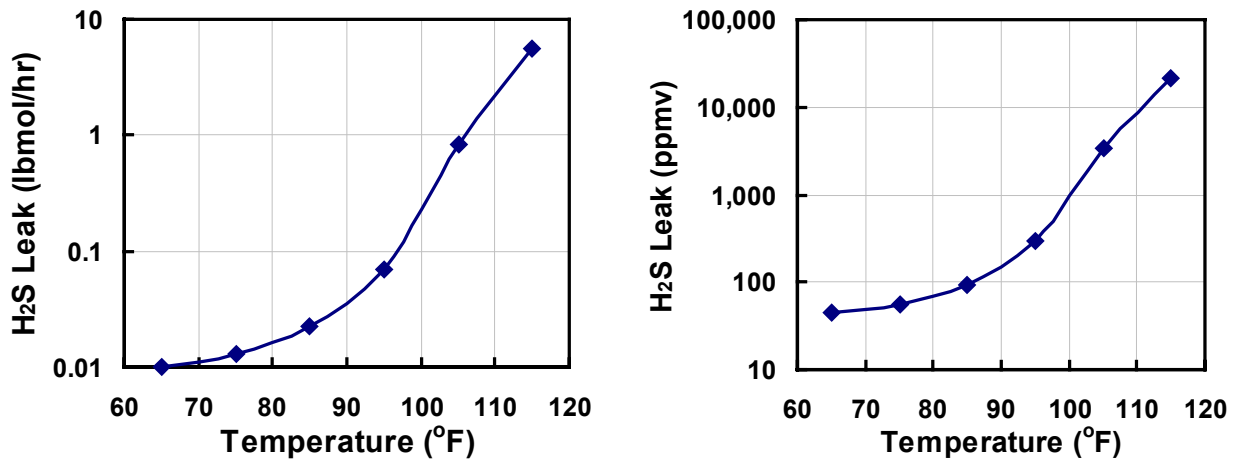

(a) H<sub>2</sub>S Leak Rate (lbmol/hr)

(b) H<sub>2</sub>S in Gas to Incinerator

Figure 7 Effect of Treating Temperature on H<sub>2</sub>S Leak for a High H<sub>2</sub>S Raw Gas

**Table 4 Effect of Varying Contactor From Base Case — High H<sub>2</sub>S Feed**

<b>Contactors Condition</b>	<b>H<sub>2</sub>S Leak (ppmv)</b>	<b>CO<sub>2</sub> Slip (%)</b>	<b>%H<sub>2</sub>S in SRU Feed</b>
<b>Base Case (13 trays)</b>	<b>93</b>	<b>92</b>	<b>80</b>
Pressure = 15 psig	34	86	70
20 trays	41	88	73
15 trays	56	91	78
13 trays	93	92	80
12 trays	154	92	81
11 trays	298	93	82
10 trays	644	94	83
Lean @ 100°F	69	94	83
<b>26 ft IMTP 50</b>	<b>34</b>	<b>91</b>	<b>78</b>
20 ft	63	93	82
15 ft	606	95	86
<b>26 ft ISP 5TX</b>	<b>23</b>	<b>82</b>	<b>64</b>
20 ft	31	86	70
15 ft	52	89	75

As a final comment, an impossibly low quality Claus plant feed (3% H<sub>2</sub>S) can be upgraded to 25 to 30% H<sub>2</sub>S in a short column, depending on how much H<sub>2</sub>S one is allowed to vent (usually set by your friendly neighborhood environmental authority). Furthermore, a sour gas with 25% H<sub>2</sub>S can be upgraded to 80% H<sub>2</sub>S, also using a fairly short column with a dozen trays or a few feet of packing. With these two columns, one can then produce 80% H<sub>2</sub>S SRU feed from a 3% gas (if the contactor can be operated at low to moderate temperatures). But *two* contactors are unnecessary—the entire upgrade can be done in a single column by using a scheme with a semi-lean stream! This is a good application for a so-called split flow process in which the *fully* stripped solvent from a common regenerator's reboiler is sent to the top of the contactor, while a *partially* stripped (semi-lean) solvent is removed from a midpoint in the regenerator and sent to an intermediate feed point part way down the absorber. This flowsheet is frequently seen in DEA and HotPot processes—perhaps super enrichment of very low quality gas is another application of the split flow configuration, albeit a more unusual one.

### **A Final Example**

The example is taken from the paper by Miller et al. (2001) dealing with the enrichment of the offgas generated by the GTU at the Aquila Navasota Gas Plant in Grimes County, Texas. The raw gas to this plant was 6.5% CO<sub>2</sub> and 25 ppmv H<sub>2</sub>S. The regenerator offgas from the GTU flowed nominally at 5.5 MMscfd and was an extremely lean AGE feed gas at 8–10 psig: it contained only 800 ppmv H<sub>2</sub>S, with the balance wet CO<sub>2</sub>. This obviously presented operations with a real problem because the H<sub>2</sub>S simply had to be removed to meet sulfur emission limits and the method in use at the time was proving to be very expensive. The paper gives a nice description of various options along with details of the amine-based solution selected. Fortunately, the paper also gives sufficient equipment and process information for process modeling, allowing direct comparison between the purely-predictive ProTreat simulation and measured plant performance data.

Table 5 compares key plant operating and performance data with simulated performance. In the simulation it had to be assumed that the reboiler duty was as stated in the design, because no measured reboiler data were given for the individual tests. Where amine strength was not reported, 45 wt% (the design value) was assumed. The circulation rate on 1/25/00 was unstated and was taken to be the same as on 1/2/00, the date of the previous performance test.

**Table 5 Operating Data and ProTreat Simulation Compared**

	<b>Design</b>	<b>11/2/99</b>	<b>11/28/99</b>	<b>1/2/00</b>	<b>1/25/00</b>
<b>Lean Amine to Absorber (°F)</b>	100	101	98	100	88
<b>Circulation Rate (USgpm)</b>	40	37.5	33	34	34 (?)
<b>Sour Gas Rate (MMscfd)</b>	5.5	4.59	4.38	4.83	5.1
<b>Treated Gas H<sub>2</sub>S Leak (ppmv)</b>	<b>166</b>	<b>144</b>	<b>169</b>	<b>170</b>	<b>130</b>
<b>ProTreat Simulated H<sub>2</sub>S Leak (ppmv)</b>	<b>151</b>	<b>132</b>	<b>158</b>	<b>171</b>	<b>148</b>
<b>Simulated Enriched Gas (%H<sub>2</sub>S)</b>	2.6	2.3	2.2	2.4	2.2

Simulated H<sub>2</sub>S leak is in every case within 10 or 15 ppmv of the reported leak, the only real performance metric reported. Given that the simulations were run using the reported operating data directly without the slightest adjustment or tweaking of any kind, the performance predictions are remarkably close to reality.

The offgas from the regenerator is not exactly rich in terms of a potential Claus plant feed. However, it has already been shown that such a gas can readily be upgraded further to 25% H<sub>2</sub>S and from there to 75% or 80% just by using additional short beds of packing or a handful of trays. A process strategy with a single regenerator and two partially- and one fully-regenerated solvent streams, i.e., three solvent streams from the single regenerator, might be a neat solution.

## Summary

Acid gas enrichment is an extreme example of applying maximum selectivity to achieve process goals. It is also a supreme test of any simulator's ability not just to model selective treating processes, but actually to *predict* their performance without recourse even to thinking about adjustable parameters such as tray efficiencies, HETP values, residence times, and the like. The predictions are made not on the basis of experience with similar processes, plants, or columns, but on the basis of fundamental knowledge and models of how trays and packings actually perform as mass transfer devices. Such knowledge, built into the simulator, provides the ability to select the right number and the right type of trays and the right amount of packing of the correct type and size to meet specific objectives.

Each of the three operating cases presented here (two using trays, and one using packing) shows that mass-transfer-rate-based simulation is capable of predicting real world performance even of such a difficult process as AGE. Unfortunately, plant performance tests of AGE operations usually do not measure the H<sub>2</sub>S content of the SRU feed, probably because of the hazards associated with handling high (and low) H<sub>2</sub>S-content gases. As far as CO<sub>2</sub> slip from the AGE contactor itself is concerned, it would be wonderful to have such data but it is next to impossible to measure reliably, unless the treated gas rate from the contactor can be measured accurately.

The work reported here indicates that from a selectivity standpoint, trays might be slightly preferable to random packing, and random packing is slightly preferable to structured packing. However, this comment must be tempered by (a) the very "slightness" of the preference, (b) the fact that when the tower height occupied by trays is replaced by the same height of packing, the packing is a more efficient mass transfer internal, and (c) the fact that the performance of each and every packing (and tray), whether random or structured, will be different from all others. Therefore, in designing an AGE process great care must be taken in deciding between trays and packing if mass transfer is the only

basis. In situations in which for one reason or another packing is preferred, further judgement must be exercised to ensure the best packing is selected. A simulator that distinguishes between packings based on their mass transfer characteristics as well as their hydraulics is an essential tool in reliable design and troubleshooting. Similar comments apply to trays, insofar as their mass transfer performance (especially the all-critical selectivity) depends on the tray vendor and mechanical details such as type of openings, number of passes and weir heights, as well as on approach to flood and hydraulic operating parameters.

Finally, this study indicates that there are no forbidden regions of operation for AGE plants except to say that the production of a super enriched Claus feed will be extremely difficult, perhaps impossible, if lean amine temperatures cannot be kept below about 100°F. Use of a stripping promoter might extend this temperature upwards a little. Ultimately, it is really a matter of being able reliably and accurately to assess whether one option or another will give satisfactory performance from both technical and economic standpoints, and then to keep the AGE unit running properly by being able to respond sensibly to inevitable process upsets, and changes in feed and ambient conditions.

## References

Anderson, M. D., Hegarty, M. J., Johnson, J. E., “Flexible Selective Solvent Design”, Paper presented to 71<sup>st</sup> Annual Convention of the Gas Processors Association, March 16–18, 1992.

Astarita, G., Bisio, A., Savage, D. W., *Gas Treating With Chemical Solvents*, John Wiley and Sons, New York, 1983.

Astarita, G., Funk, E. W., Savage, D. W., Yu, W. C., “Selective Absorption of H<sub>2</sub>S and CO<sub>2</sub> into Aqueous Solutions of Methyldiethanolamine”, *I. & E. C. Fundamentals*, 25, 326 (1986).

Dibble, J. H., European Patent Publication Number 0134948, Application Number 8417586.4, March 27, 1985 [from Kohl and Nielsen, 1997].

Johnson, J. E., Chapin, D. W., Hegarty, M. J., Spath, P. L., “Enrich Your Sulfur Recovery Experience”, Paper No. 56 presented at Spring National Meeting of AIChE, New Orleans, LA, Mar 29–Apr 2, 1992.

Johnson, J. E., Wissbaum, R. J., “Gas Treating Design for Improved Sulfur Recovery”, Paper presented at Sulphur 98, Tucson, AZ, Nov 1–4, 1998.

Kohl, A. L., Nielsen, R. B., Table 2-18, p. 132 in *Gas Purification*, 5th Edition, Gulf Publishing Corp., 1997.

Miller, D. T., Roesler, K., Holub, P. E., McCaffrey, C., Covington, K., “Unique Acid Gas Enrichment Application”, Laurence Reid Gas Conditioning Conference, Norman, OK, 2001.

Weiland, R. H., Sivasubramanian, M. S., Dingman, J. C., “Effective Amine Technology: Controlling Selectivity, Increasing Slip, and Reducing Sulfur”, Laurence Reid Gas Conditioning Conference, Norman, OK, 2003.