

# TRAY HYDRAULIC OPERATING REGIMES AND SELECTIVITY

*Ralph H. Weiland  
Optimized Gas Treating, Inc.  
Clarita, OK*

## ABSTRACT

Most gas treating contactors are highly liquid loaded, with good designs operating at vapor loads approaching the jet-flood limit. An optimal design also will have downcomers sized to approach the choke flood limit at the design point because this allows for the maximum tray active area, hence the smallest column diameter for a given throughput. At high weir liquid loads, trays operate predominantly in the froth regime where the gas dispersion rises through continuous liquid, interfacial areas are large, and the liquid is highly agitated. This results in high absorption efficiency for both CO<sub>2</sub> and H<sub>2</sub>S. Low weir loads correspond to the spray regime where the liquid is dispersed as rather large droplets that are projected through a continuous gas phase as a spray. The droplets behave like nearly stagnant, rigid spheres and they have extremely small liquid-side mass transfer coefficients. Consequently, CO<sub>2</sub> absorption is severely retarded because its rate is controlled by the liquid-side resistance to mass transfer. This provides a concomitant improvement in H<sub>2</sub>S removal.

A number of cases have come to light in which seemingly impossibly-low H<sub>2</sub>S leak rates have been realized and much higher than normal CO<sub>2</sub> rejection rates observed from trayed columns. In every case, liquid rates were low and the weirs were long enough to have weir loads of 10 gpm/ft or less, putting the trays well into the spray regime. Simulations could be matched to plant performance data only by (1) using greatly reduced liquid-film coefficients for mass transfer (stagnant liquid), and (2) increasing the gas-side coefficient as expected for turbulent gas flow past drops.

The spray regime is quite effective in achieving ultra low H<sub>2</sub>S leaks and greatly improved CO<sub>2</sub> rejection rates, and if conditions cause an existing plant to operate there, selectivity will probably greatly exceed what normally might be anticipated. Therefore, if processing goals and certain other circumstances are right, consideration should be given to operating in this region.

## Introduction

Usually, contactors containing trays are initially designed to operate at 70 to 80% of jet and downcomer flooding rates using very conventional valve-type trays with few or no hydraulic performance enhancers such as tapered downcomers and swept-back weirs. These are safe designs because they use old and tried technology and leave plenty of room for easy capacity improvement should they fall short in the field or to accommodate the inevitable, future increases in plant throughput. Most contactors in gas treating applications have relatively high liquid to gas (L/G) ratios, usually quite a bit higher than in distillation, because the large amounts of acid gases to be removed require large solvent flows for absorption. A well-designed tray has a turndown ratio of at

least 4:1; in other words, it can operate satisfactorily from a hydraulic standpoint down to about one quarter or less of design rates. Below about a four-to-one turndown, liquid starts to weep through the trays to an extent that mass transfer performance might begin to suffer. At the liquid to gas ratios common in gas treating, trays normally operate in the froth regime. The biphasic on the tray has its gas dispersed within a more or less continuous liquid, and the mixture flows across the tray as an intensely-agitated froth.

Sometimes a raw gas contains either very small amounts of H<sub>2</sub>S and CO<sub>2</sub>, or perhaps a small concentration of H<sub>2</sub>S and a larger fraction CO<sub>2</sub>, but the H<sub>2</sub>S must still be removed to meet a parts-per-million specification. In such cases, only very modest solvent flow is needed to treat the gas with N-methyldiethanolamine, MDEA, (an amine that is fairly selective towards H<sub>2</sub>S) so the liquid to gas ratio in the contactor is low. As the liquid flow is reduced, the froth gives way to a spray because there is insufficient liquid flow to maintain a reasonable volume of liquid on the tray. The still large vapor flow shatters the liquid, converts it to droplets and ejects it into the vapor space, and eventually the downcomer, not as a stream of continuous liquid flowing over a weir, but as a swarm of drops—a spray—thrown over the weir. What is important to realize is that the phase hydraulics, the interfacial areas, and therefore gas- and liquid-side mass transfer coefficients, can be radically different in the froth and spray regimes, resulting in the likelihood that selectivity will be significantly affected<sup>1</sup>.

## Tray Hydraulics

Maximum tray hydraulic capacity can be limited by any one of three types of flooding: (a) jet or entrainment flood, (b) downcomer backup flood, and (c) downcomer choke flood. The ability of a tray to operate at the lower end of the loading range is limited by (d) weeping and also by (e) entrainment that occurs even in the spray regime of operation as the liquid flow on the tray is decreased while maintaining a high vapor flow rate. The other low liquid rate limitation is vapor bypassing up downcomers as lowered liquid depths unseal the downcomers. In a perfectly balanced design, jet flood and choke flood will occur simultaneously and the column's diameter will be sized to be slightly more than adequate for the proposed loads; certainly pressure drop will not be high enough nor downcomer clearance tight enough to induce backup flood problems, nor will vapor bypass up downcomers.

### Entrainment Flood

Figure 1 is a typical tray operating diagram showing stable limits. The portion of the upper operating line labeled Entrainment Flooding is in the Froth Regime and it corresponds to the upper limit of vapor flow where the tray begins to flood, the so-called jet flood line. This should not be interpreted as a finely drawn, sharp line because the definition of jet flood varies from vendor to vendor. Some vendors call 85% jet flood the vapor velocity at which 10% of the liquid is entrained from the tray and flows with the vapor to the tray above. Others call it the maximum useful capacity. Whether the definition is 80% or 90% jet flood corresponding to 10% or 20% entrainment is arbitrary and the pinpointing of maximum useful capacity is certainly subjective. However, near the jet flood limit the entrainment rate is exponentially sensitive to small changes in vapor rate and

---

<sup>1</sup> Selectivity for H<sub>2</sub>S over CO<sub>2</sub> is the direct result of the facts that (1) H<sub>2</sub>S and CO<sub>2</sub> absorption rates are respectively controlled by vapor-side and liquid-side resistances to mass transfer and (2) the extreme slowness of the reaction of MDEA with CO<sub>2</sub> which leaves the CO<sub>2</sub> absorption rate almost completely unenhanced by reaction. Mass transfer rates, of course, are directly dependent on the mass transfer coefficients that pertain to each transferring species.

only a small increase in vapor flow will cause the column to flood. This is not a condition at which one would like to operate because the column approaches instability and becomes harder to control.

Vapor load is best described by the C-factor, usually based on the superficial vapor velocity,  $u_s$ , through the empty column but sometimes based on the gas velocity through the tray active area or even through the area of the actual openings (valves, etc.). The superficial-velocity definition is

$$C_s = u_s \sqrt{\frac{\rho_V}{\rho_L - \rho_V}}$$

A conventional valve tray with 13% straight downcomers operating at normal weir loads (50 – 150 gpm/ft) will flood when  $C_s$  is much above 0.38 ft/s. A more-modern high-capacity tray uses special downcomer treatments to recover much (and in the case of truncated downcomers, all) the area under the inlet downcomer, so it enjoys between a 10% and 20% higher capacity. This higher jet flood capacity is achieved simply by converting more of the tower area into tray active area.

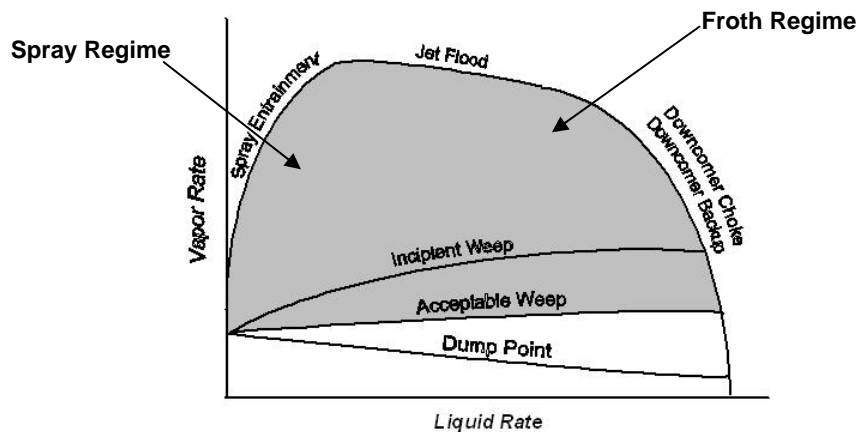

**Figure 1 Tray Operating Diagram (adapted from Kister, 1992, p. 269)**

One jet flood mechanism is froth entrainment by gas which carries liquid to the tray above in large enough quantities that downcomer capacity is exceeded on the top tray<sup>2</sup>. However, froths on operating trays are not well-behaved flows of uniform depth—massive eruptions and geysers occur with high frequency, with the liquid being thrown against the bottom of the overlying tray and forced through its perforations. At close tray spacing the froth may occupy the whole space between the trays: flooding occurs when the froth tries to expand even further. This may not be limited to close tray spacing—it is hard to make more than a slight distinction between froth occupying the whole volume between trays and numerous geysers throwing liquid at the upper tray. Of course, when foaming occurs, the whole jet (and downcomer) flood situation is exacerbated in the extreme.

<sup>2</sup> Except for the bottom-most and top-most trays, each tray in the column receives as much entrainment from the tray below as it loses to the tray above so it experiences very little change in liquid load caused by entrainment. The bottom tray actually has a lower liquid load than any other tray in the column because it receives no entrainment from below but loses liquid to the tray above. However, the top tray has most of its entrainment returned to it by the mist pads commonly installed in the top of the tower so the liquid load on the top tray is incremented by the entrainment rate from the tray below. Thus, the top tray has the highest liquid load and would be expected to flood first.

## Downcomer Flood

Downcomers can flood by two possible mechanisms: excessive liquid backup inside the downcomer (backup flood), and choke at the downcomer mouth. The right-hand-side of Figure 1 does not distinguish between the two mechanisms, and indeed, it is often hard to distinguish between them even visually in a large-scale, well-instrumented pilot plant.

### Backup Flood

As shown in Figure 2(a), the depth of liquid (or froth) in a downcomer is determined by (a) liquid depth on the tray, (b) the pressure drop across the tray and (c) the head loss for flow of aerated liquid under the downcomer skirt. The third factor can be controlled by using the right downcomer escape area but the second depends on tray pressure drop which is a function of the tray bubbling area, the type of tray opening being used, and the fractional hole area. Backup flood is the easiest to avoid.

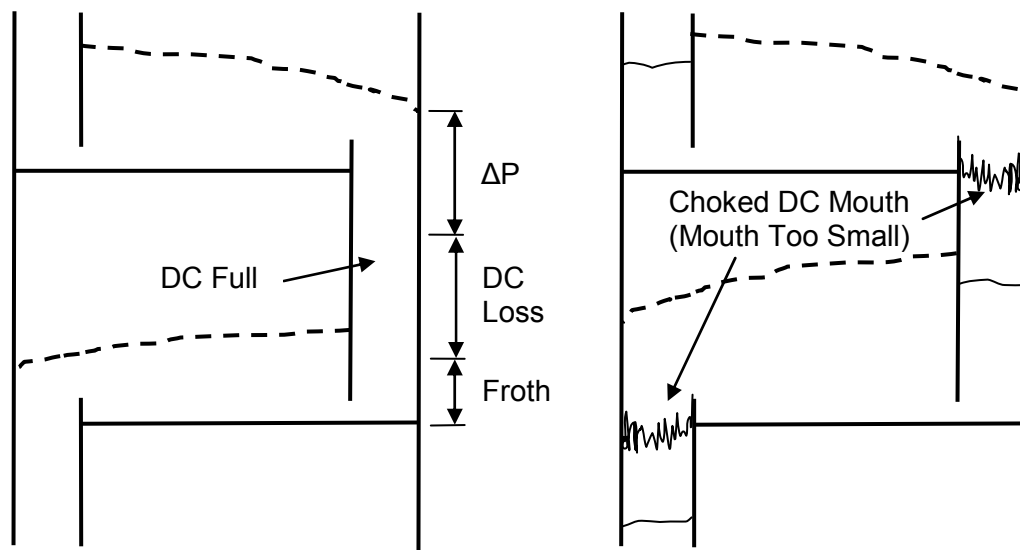

(a) Backup Flood

(b) Choke Flood

Figure 2 Two Types of Downcomer Flooding (adapted from Kister, 1992, p. 272)

### Choke Flood

The cross-sectional area (and to a lesser extent the shape) of the downcomer mouth is the primary factor that determines its capacity for accepting a given flow of liquid or froth. Referring to Figure 2(b), at choke, liquid does not crest over the weir. Instead, the downcomer is simply presented with a higher volume flow of froth than can be driven into it when hydrostatic head is at its greatest, equal to the tray spacing (the maximum head possible). Once the downcomer mouth becomes covered with froth, liquid height over the weir is no longer proportional to volume flow to the  $2/3^{\text{rds}}$  power as in the Francis weir formula. Instead, liquid height over the weir becomes proportional to liquid rate raised to the 1.5 power; thus, any further increase in liquid flow requires *greatly* increased head to drive the flow into the mouth. Once the downcomer mouth becomes buried in froth, only small increases in liquid load are enough to throw the column into choke flood—the column becomes increasingly unstable and eventually impossible to operate<sup>3</sup>.

<sup>3</sup> During a foaming event, perhaps downcomer choke flood might be considered the culprit because the froth volume is much increased, with the downcomer being asked to admit a greatly increased volume flow of even lower density material. Under choke conditions even a large increase in froth depth drives only a modestly increased flow. But this is

## Weeping Through Tray Openings

Referring again to Figure 1, as the gas rate is decreased at a fixed liquid rate, a point is reached at which the tray starts to weep. This is the incipient weep point where the first droplets of liquid find their way downwards through a few perforations. Further decreases to vapor rate result in increased weep rates until the weep rate becomes, in some sense, excessive. Perhaps surprisingly to distillation experts, there have been instances where during a turnaround all the trays in a conventional 20-tray contactor have been found in a heap in the tower sump, yet the column was making on-specification gas (usually total acid gas removal) at design rates just before the turnaround! Obviously what defines a weep rate as excessive depends very much on the operation. However, when slipping  $\text{CO}_2$  is important or meeting *both* an  $\text{H}_2\text{S}$  and a  $\text{CO}_2$  specification is the objective, the column must be more tightly designed. Too much weeping compromises the separation because to some extent it spoils the split between  $\text{CO}_2$  and  $\text{H}_2\text{S}$ .

## Spray Regime

Kister and Haas (1987) have shown that entrainment rate goes through a minimum with weir liquid load (Figure 3). The minimum might be considered to be somewhere in the transition between the froth and spray regimes, the spray regime lying to the left. However, the transition itself is very gradual so there is no “point” associated with it. The spray regime is entered at higher liquid rates in hydrocarbon systems (cyclohexane–n-heptane in the Figure) than in air-water (much closer to amine treating fluids). The higher the gas rate, the higher the weir load at transition; however, unless the tray is operating at an extremely low vapor rate, transition to the spray regime occurs at a weir liquid load (volume liquid flow per lineal length of weir) between 15 and 30  $\text{gpm/ft}$  and the entrainment rate climbs super exponentially as liquid load is further reduced.

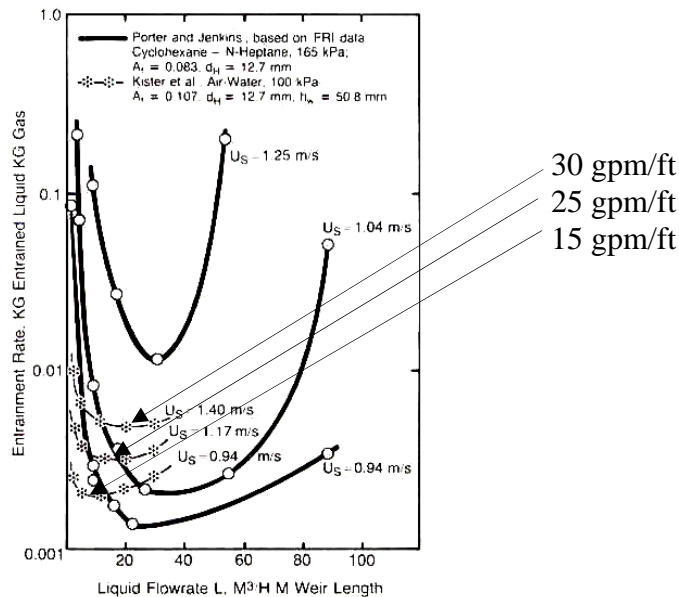

**Figure 3** Dependence of Entrainment Rate on Weir Load at Various Gas Rates for Cyclohexane – n-Heptane and Air–Water (Kister & Haas, 1987)

speculation because once flooding begins, it is extremely hard to ascribe one mechanism or another as the cause—they are all connected.

In terms of mass transfer, the gas-liquid interfacial area per unit volume of spray can be expected to be smaller than the same area in good-quality, deep froth. The droplets, being small and probably containing some amount of contamination as well, exhibit the internal hydraulics of essentially rigid spheres. This means that the transfer of acid gases into the interior of the drops must take place by purely molecular diffusion, a very slow process compared with transfer into the highly-agitated, turbulent liquid in froth. Also, as noted by Lockett (p. 39, 1986), photographic evidence indicates that drop breakup and coalescence does not occur during flight so even this method of getting dissolved gas into the drop's interior is not available. Thus, the liquid-side mass transfer coefficient might be expected to be *very* much smaller than in a froth. Because CO<sub>2</sub> absorption is controlled largely by resistance in the liquid phase, the liquid-side mass transfer coefficient for CO<sub>2</sub> absorption, and therefore the CO<sub>2</sub> absorption rate itself, should be seriously reduced, i.e., a great deal more CO<sub>2</sub> should be rejected and CO<sub>2</sub> slip significantly increased.

It is perhaps less easy to speculate on the effect of spray-regime operation on gas-side mass transfer resistance. In surface-tension-negative systems (where surface tension decreases as liquid flows down the column), higher distillation efficiencies are observed in the spray regime (distillation is generally controlled by vapor phase resistance) because smaller drops are produced. However, gas treating is a surface-tension-neutral system. So surface tension effects probably do not pertain. However, highly turbulent gas flow past drops is markedly different from gas bubbles and jets sparging into and rising through liquid. Unconfined gas flow past large drops probably is much more turbulent than gas in froth, especially near the interface, so higher gas-side mass transfer coefficients might be anticipated. Flow past spheres transitions from laminar to turbulent at a Reynolds number of about unity. At atmospheric pressure, a 1-mm drop (typical of a spray, Kister, 1992, p. 292) has a terminal velocity of about 7 m/s and falls at a Reynolds number of about 500, i.e., in the fully-turbulent region. It is not hard to imagine that fully turbulent flow past a myriad of drops results in large values for the gas-side mass transfer coefficient since molecular diffusion through the gas plays a role only quite close to the drop surface where concentration gradients are unavoidably very steep.

The point is that the spray and froth regimes present completely different types of fluid flow and, because hydraulics is one, if not the, major determining factor for mass transfer, the mass transfer performance in these two regimes ought to be very different. The effect of the difference is highly magnified in selective gas treating. Does this really lead to differences in CO<sub>2</sub> slip and, therefore, H<sub>2</sub>S absorption? The two sets of plant performance data presented next suggest that indeed it does.<sup>4</sup>

## Simulation and Field Data

Before embarking on using the ProTreat™ simulator's mass transfer rate-based column model to explain why certain treating plants with absorbers operating in the spray regime have been observed in the field to perform so much better than they "should", it is important to be convinced that simulation is capable of truly *predicting* plant performance at all.

---

<sup>4</sup> It should be noted that operating in the spray regime can result in reduced tray vapor-handling capacity unless the tray is carefully designed. There are ways to regain froth regime operation if this is desired. One is to reduce the number of tray passes—one of the main reasons for using multiple tray passes in the first place is to *reduce* excessive weir loads but, if the weir loads are already too small, using multiple passes is counterproductive and fewer passes should be used. The other approach is to use so-called weir blocks, or picketed weirs, which effectively shortens the weir length by placing a series of vertical barriers (pickets) on the weirs to force part of the liquid spray back onto the tray and make the effective weir length shorter.

™ ProTreat is a trademark of Optimized Gas Treating, Inc. Other trademarks are the property of their owners.

## Predicting Plant Performance

A mass transfer rate-based column model uses the fundamental *mass transfer* characteristics of the specific tower internals (hydraulic- and property-dependent, phase, mass transfer coefficients of trays, random packing, and structured packing) together with phase equilibrium and reaction kinetics to calculate the actual mass transfer *rates* of individual species occurring between the liquid and vapor phases flowing on real trays and through packed beds. The approach is completely analogous to the way heat transfer calculations have been done and heat exchangers have been designed for nearly a century. The real difference is the transferring entities: heat in one case and chemical species in the other, so temperature differences are used in one case and concentration differences in the other. Where heat exchangers' heat transfer properties are correlated, for example, in terms of shell and tube-side heat transfer coefficients as functions of exchanger hydraulics and the transport properties of the heated and cooled streams, the mass transfer properties of trays and packing are correlated as liquid-side and vapor-side mass transfer coefficients, again as functions of hydraulics and the transport properties of the two phases. The analogy is strong. Phase equilibrium and the number of species make mass transfer calculations a lot more challenging than heat transfer but this is only a computational technicality—if the underlying correlations themselves are reliable, heat-transfer-rate and mass-transfer-rate models predict equipment performance with equal trustworthiness and fidelity. *Engineers don't use efficiency-corrected equilibrium heat exchanger models, and there is no longer necessary to use their mass transfer equivalent in tower design.* This is especially the case in amine treating where different phases dominate the absorption rates of each component, the components have very strong thermodynamic interactions via chemical reactions, and the component-dependent tray efficiencies typically range from a few percent to 20%.

The mass transfer rate-based approach to column simulation as implemented for example in Aspen Plus<sup>®</sup> and Pro/II<sup>™</sup> under the name RATEFRAC<sup>®</sup> (a general purpose module), by several solvent vendors, and within ProTreat<sup>™</sup> (specifically for gas treating), has been used to simulate hundreds of columns around the world with outstanding success. The approach has been in continuous commercial use for some 20 years, so there can be little doubt that it is a sound one. The advantage of mass transfer rate-based simulation is that it is truly and reliably *predictive*, without leaning even slightly on any knowledge of plant performance to tweak the model in order to get the right results. Today, the mass transfer simulation of columns is on just as solid a footing as the heat transfer simulation of heat exchangers and the calculation of pressure drop through piping networks.

## Case Studies

Both case studies involve plants that are treating raw gas having parts per million H<sub>2</sub>S, in the first case 60 ppmv and in the second 240 ppmv. Both plants produce treated gas having about 1 ppmv H<sub>2</sub>S and, because neither is treating gas containing a lot of CO<sub>2</sub>, only low solvent rates are necessary to process the gas. In other words, the contactors in these plants are operating with unusually low L/G ratios.

### Case Study 1

INEOS<sup>\*</sup> GAS/SPEC<sup>\*</sup> SS-3 solvent at 45 wt% strength is used to treat gas containing 60 ppmv H<sub>2</sub>S and 0.94 mol% CO<sub>2</sub> at about 460 psig. Figure 4 shows the flowsheet.

---

\* INEOS and GAS/SPEC are trademarks of INEOS Oxide, a division of INEOS Americas, LLC

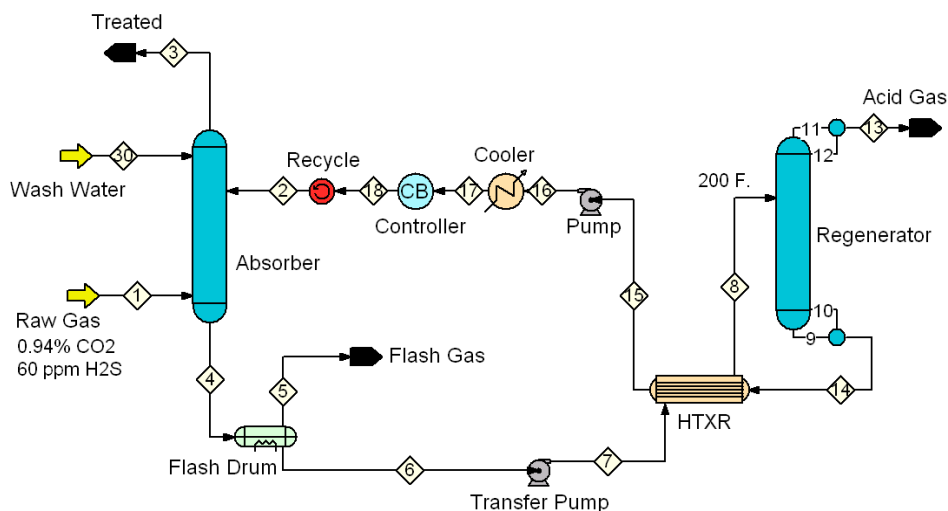

**Figure 4 PFD for Case Study 1**

Straightforward simulation of this process predicts that the treated gas should contain 27 ppmv H<sub>2</sub>S and the CO<sub>2</sub> level should have been reduced to 0.636 mol% with the rich amine loaded to 0.634 moles of CO<sub>2</sub> per mole of SS-3 solvent. However, a series of carefully planned and executed plant trials showed unequivocally that the raw gas, varying between 50 and 70 ppmv H<sub>2</sub>S was actually treated to between 1.0 and 1.2 ppmv H<sub>2</sub>S and the treated gas was consistently at 0.865 mol% CO<sub>2</sub> (93% CO<sub>2</sub> slip!) with a rich solution CO<sub>2</sub> loading of only around 0.13 mol/mol. The simulation results weren't even close to reality!

These are 1-pass valve-type trays and because of the low L/G ratio they have only 5% downcomers, i.e., 90% active area. The trays run at about 50% of jet flood with the downcomers at only 11% of choke flood. Jet flood and choke flood are not issues. The striking hydraulic parameter, however, is the weir load—only 11 gpm/ft. At a superficial gas velocity of 1.27 ft/s, this puts the trays into the spray regime of operation; on the other hand, the simulation is based on mass transfer characteristics that pertain to the froth regime<sup>5</sup>. The measured plant data are accurately reproduced by the simulation if the liquid-side and gas-side coefficients are decreased and increased, respectively, by a factor of 10. The simulated results in this particular case were not very sensitive to reasonable changes in interfacial area. It is interesting to note that decreasing the liquid-side coefficient alone produced the observed CO<sub>2</sub> slip and also resulted in a significant (albeit insufficient) improvement in H<sub>2</sub>S pickup because less solvent was used up by over-absorption of CO<sub>2</sub>. A further significant increase in gas-side mass transfer coefficient was needed to reach the observed H<sub>2</sub>S treat.

### Case Study 2

For this case, only data for the contactor were available. A lower pressure gas (155 psig) was being treated than in Case 1, using a solvent mixture comprising 19.15 wt% MDEA and 10.85 wt% DEA (30 wt% total amine) flowing at only 5 gpm to the contactor. The raw gas contained 2.1

<sup>5</sup> Much work has been reported on the froth-to-spray *transition*. However, no work appears ever to have been done, and none has been reported, which measures such fundamental mass transfer parameters as film coefficients and interfacial areas for mass transfer in the spray regime, possibly because the general recommendation is not to operate there. Therefore, *all mass transfer rate*-based simulators do their calculations using mass transfer characteristics that pertain to froths, and this takes care of the overwhelming majority of operating distillation and absorption columns.

mol% CO<sub>2</sub> and 240 ppmv H<sub>2</sub>S. Lean amine CO<sub>2</sub> and H<sub>2</sub>S mole loadings were 0.0136 and 0.0005, respectively. The H<sub>2</sub>S leak from the absorber was measured to be 1 ppmv and the treated gas contained about 1 mol% CO<sub>2</sub>. However, simulation based on froth-regime, mass-transfer coefficients predicted 23 ppmv H<sub>2</sub>S and 0.72 mol% CO<sub>2</sub>. Again, too much CO<sub>2</sub> pickup is predicted and, partly as a consequence, simulated H<sub>2</sub>S removal is too low by a very substantial margin. The hydraulic calculations gave a weir liquid load equal to the amazingly-low value of 2.8 gpm/ft, making the spray regime an absolute certainty. There were no special weir treatments. But, just as in Case 1, if the liquid-side and gas-side coefficients are decreased and increased, respectively, by a factor of 10, the plant data are perfectly matched by the simulation. It should be mentioned that the trays in this example were turned down to only 11% of jet flood so serious weeping was possibly another issue; nevertheless, regardless of whether there was weeping or not, the liquid was definitely in the form of a spray and spray regime mass transfer corrections should apply. The results indicate that indeed they do.

Factors of 10 changes in individual phase mass transfer coefficients are certainly not small. However, it should be realized that the flows of the phases change from turbulent to stagnant in the case of the liquid, and from *relatively* quiet for gas bubbles to very turbulent near drop surfaces in the case of the gas. The size of the corrections emphasizes the radical difference in the flows.

## Discussion

For the most part, gas treating engineers seem unaware of the important distinction between spray and froth regimes of tray operation, and the effect of weir load in determining where a given set of trays actually operates. More importantly, the impact of froth versus spray flow regime on *selective* performance appears never before to have been addressed quantitatively. However, the idea that a laminar or stagnant liquid will promote CO<sub>2</sub> rejection is certainly not new. Sigmund and Butwell (1981) for example developed a special tray intended to produce a laminar liquid flow with the specific objective of increasing CO<sub>2</sub> slip and, therefore, improving H<sub>2</sub>S removal rates. Their idea was to produce laminar liquid jets on trays, with the liquid flowing into truncated downcomers with perforated bottoms. Although a version of their tray design was installed in a New Mexico gas plant owned by El Paso Natural Gas, no serious effort seems to have been made to commercialize this patented tray.

The *normal* weir loading range for conventional trays is from roughly 40 or 50 gpm/ft to about 150 gpm/ft. Modern high-performance trays have superior capacity because they trade downcomer area for active area but there is no reason to believe maximum operable weir loads are any higher than a conventional tray. In gas treating applications L/G ratios are generally high because most gases contain high concentrations of acidic components and the solvents have limited capacity, so high solvent rates are required relative to the gas flows being treated. Furthermore, except in tail gas treating and more recently CO<sub>2</sub> capture from power plant flue gases, treating pressures are usually in the 100s of psi range. These factors make spray regime operation rare in gas treating, perhaps explaining the general lack of appreciation for the very existence of this regime.

The two cases discussed here presented quite a puzzle when they first came to light. It just seemed physically impossible to produce 1 ppmv H<sub>2</sub>S gases under the stated conditions and slip as much CO<sub>2</sub> as was claimed. No amount of supposition about such things as possible effects of solvent contamination and tray damage made any sense. Perhaps a gamma scan might have led to earlier resolution; however, in both cases the contactors were treating the gases perfectly satisfactorily so there was certainly no commercial incentive to spend money diagnosing a non-problem. The inquiry was driven by the failure of the simulations to come even close to measured

performance. It was intriguing that simulation of these two plants, operated by different companies and using quite different solvents, showed such closely similar deviations from measured performance.

When more detailed tray hydraulic calculations were done, it became blatantly evident that in both cases the contactors were operating well into the spray regime<sup>6</sup>. Therefore, the basic mass transfer coefficients used in the simulations were almost certainly at fault. Confirmation of this thinking was that the simulations required virtually identical adjustments of basic mass transfer coefficients to bring the results into close conformity with measurements. One of the outcomes is that much more detailed tray hydraulic calculations are now done as a routine part of ProTreat simulations.

Very low L/G ratios are rare in gas treating. However, in instances where they exist, much increased CO<sub>2</sub> rejection and far better H<sub>2</sub>S removal seem to result. So, should spray regime operation be encouraged (for example, by using multi-pass trays with long weir lengths when a one-pass tray is sufficient) as a means to promote better selectivity in gas treating? Because of the normally high L/G ratios common in gas treating, there is only infrequent opportunity to consider such an approach, at least using conventional trays. Furthermore, conventional “wisdom” is to stay away from this region<sup>7</sup>, supposedly because entrainment rates are higher, so superficial gas velocity would have to be reduced (tower capacity sacrificed), necessitating a more-expensive, larger-diameter tower. However, be this as it may, there are circumstances such as the ones in the Case Studies reported here, where a very significant advantage can be had by purposefully operating in the spray regime. Indeed, two of the world’s highest capacity (and most expensive) trays, Shell’s ConSep™ tray and the Koch-Glitsch ULTRAFRAC® tray are in a sense co-current flow trays by design, and both operate primarily in the spray regime over their entire operating range. These trays might be attractive for obtaining selectivities in a range well beyond the reach of conventional cross-flow trays although their cost effectiveness would certainly be application dependent. Nevertheless, using quite conventional trays, some selective contactors have been enjoying the great selectivity benefits of the spray operating regime for years—what is new is knowing the reason for their success. Understanding certainly does not increase risk—it decreases it—so where possible, there is a real incentive to operate in the spray regime because selectivity is tremendously improved.

Although trays are often not the best choice of tower internals for very low L/G operations, in the present case, simulation and experience indicate that when it comes to selectivity neither random nor structured packing can come even close to trays operating in the spray regime.

## Literature Cited

Kister, H. Z., *Distillation Design*, McGraw-Hill, Inc., New York, NY, 1992.

Kister, H. Z., and J. R. Haas, *I. Chem. E., Symp. Ser.*, 104, p. A483 (1987).

Lockett, M. J., *Distillation Tray Fundamentals*, Cambridge University Press, 1986.

Sigmund, P. W., and K. F. Butwell, US Patent 4,278,621, July 14, 1981.

---

<sup>6</sup> The trays used in these studies were not designed specifically for extremely low weir loads and spray regime operation. However, they used inlet sumps so vapor bypassing up the downcomers was not likely an issue.

<sup>7</sup> The author thanks Henry Z. Kister for pointing out just how ill-founded this conventional wisdom really is. In fact, trays can have even higher capacity in the spray than in the froth regime *if they are properly designed*. Obviously, downcomers must be designed to remain sealed without reliance on the outlet weir; an obvious way to do this is to use a sufficiently deep inlet sump.