

Treating high CO₂ gases with MDEA

Using MDEA as a solvent for high levels of CO₂ removal requires careful process modelling using accurate simulation

Jenny Seagraves *Ineos Oxide*

Ralph H Weiland *Optimized Gas Treating*

Generic *N*-methyldiethanolamine (MDEA) is commonly used as a highly selective solvent to treat sour gases down to parts-per-million levels of H₂S while slipping a large proportion of the CO₂ in the feed gas from the system. It is also the major constituent in many speciality amine formulations developed for deeper CO₂ removal in applications such as synthesis gas production and treating high CO₂ natural gases found in several regions of the world. However, in recent years, attempts have been made to use solvents containing MDEA alone for CO₂ removal from high concentration gases, usually at high pressure.

A number of treating plants have been designed and built around using generic MDEA for treating high CO₂ gases. However, there is a limit to how much CO₂ removal can be achieved using generic MDEA in a column of reasonable height or tray count. Unfortunately, several CO₂-only plants have failed to meet treating requirements or have encountered treating difficulties as a result of the choice of solvent. In many cases, these plants have had to be retrofitted to speciality amines, and sometimes they have had to undergo expensive tower revamps in order to correct the problems.

This article is intended to help prevent future failures by exploring the limitations of using generic MDEA for CO₂ removal applications. Through case studies that use plant performance data, it demonstrates what is possible and what is not.

Understanding the process

In most treating applications for removing CO₂ as the only acid gas constituent, the choice of MDEA as the sole active ingredient in the solvent is likely to be unsatisfactory, except in cases where only a small amount of CO₂ removal is needed. To make correct, rational decisions on solvent selection, it is helpful to understand why this is the case.

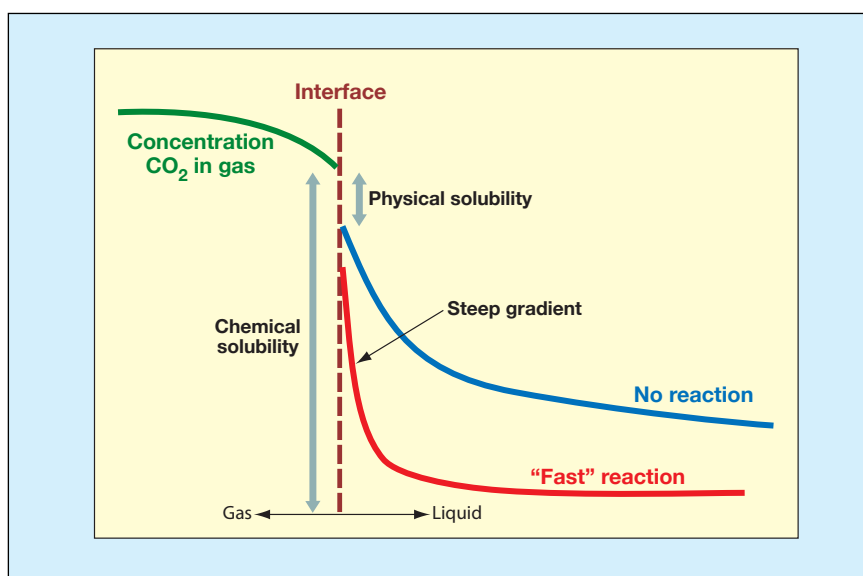
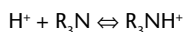
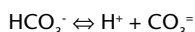
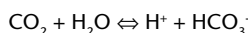

Figure 1 Typical concentration profiles for CO₂ in the gas and liquid phases when there is no reaction and when the reaction is relatively fast

MDEA is a tertiary amine whose amine group lacks even the single proton that is so essential to react directly with CO₂. In terms of its chemistry, the most that MDEA can do is provide a sink for the hydrogen ions produced when CO₂ hydrolyses in water:



Although CO₂ does not react with MDEA, when you measure the effect of MDEA on the absorption rate of CO₂, the results can be interpreted in terms of chemical reaction rate parameters for the so-called “apparent” reaction between CO₂ and MDEA. This apparent reaction is found to be first order in both MDEA and CO₂ with a very small, albeit non-zero, value for the reaction rate constant. There is no question that MDEA is unable to react directly with CO₂, because it cannot form a reaction product (such as the carbamated form

that results with primary and secondary amines). Instead, it is said to catalyse the hydrolysis reaction of CO₂. But even when catalysed, the CO₂ hydrolysis reaction is extremely slow, so slow in fact that it barely affects the CO₂ absorption rate at all. In other words, unlike primary and secondary amines, the apparent reaction kinetics of MDEA does not have much impact on the rate of the absorption process.

MDEA's real role is to provide an enormous sink for protons produced by slow CO₂ hydrolysis. Thus, while the capacity of MDEA solutions for CO₂ is very high, the absorption rate is so low that this capacity is rarely realised in practice, unless the chemistry is enhanced by means of a promoter. The reason for low absorption rates can be clarified by considering the effect of chemical reaction on absorption, and what the driving force for absorption really is.

There are two kinds of solubility that are important: the physical solubility of CO₂ in the solvent (the solution is rarely less than 90 mol% water in commercial

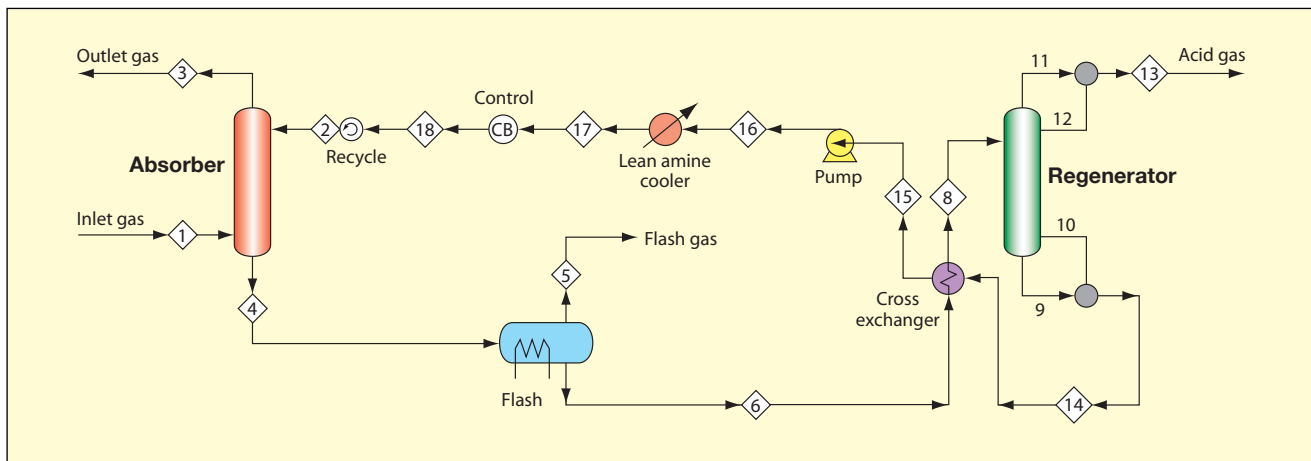

Figure 2 PFD of plant for case study 1

Simulated performance with 2 inch and 5 inch weirs

| | Equilibrium-stage-based mode | | ProTreat mass-transfer model | |
|---|------------------------------|---------------------|------------------------------|---------------------|
| | 2 inch (50mm) weir | 5 inch (125mm) weir | 2 inch (50mm) weir | 5 inch (125mm) weir |
| Inlet gas flow, MMscfd (Nm ³ /s) | 10 (3.28) | 10 (3.28) | 10 (3.28) | 10 (3.28) |
| Inlet pressure, psig (barg) | 765 (52.7) | 765 (52.7) | 765 (52.7) | 765 (52.7) |
| Inlet temperature, °F (°C) | 110 (43) | 110 (43) | 110 (43) | 110 (43) |
| Inlet CO ₂ , mol% | 9.5 | 9.5 | 9.5 | 9.5 |
| Outlet CO ₂ , mol% | 0.68 | 0.20 | 2.08 | 1.72 |
| MDEA strength, wt% | 50 | 50 | 50 | 50 |
| Lean amine, USgpm (m ³ /h) | 130 (29.5) | 130 (29.5) | 130 (29.5) | 130 (29.5) |
| Lean amine temperature, °F (°C) | 120 (49) | 120 (49) | 120 (49) | 120 (49) |

Table 1

MDEA solvents); and the equilibrium solubility of CO₂ in the treating solution as it is measured in the laboratory (which we will call the chemical solubility). The physical solubility is quite low and is properly calculated from Henry's Law for CO₂ in water, modified somewhat for the effect the amine has in replacing up to 10 or 12 mol% of the water with a component (the amine) in which the physical solubility of CO₂ is considerably higher. The chemical solubility, on the other hand, is extremely high because MDEA protonation allows very high bicarbonate and carbonate concentrations to be formed.

The absorption of CO₂ occurs in a series of steps: diffusion from the gas to the gas-liquid interface; gas dissolution into the liquid at the interface; possible chemical reaction with the amine; and diffusion of the dissolved gas in both its free and reacted forms away from the interface and into the bulk of the liquid. Figure 1 shows typical concentration gradients of CO₂ diffusing through the gas and the liquid when there is no reaction (shallow gradient) and relatively fast reaction (steeper gradient that enhances the diffusional mass transfer rate).

The process of dissolving is physical and its rate is determined by the physical solubility of the gas right at the interface.

Diffusion away from the interface through the liquid takes place under a concentration driving force, which is the concentration gradient of the unreacted (but maybe still reacting) gas. Reaction steepens the concentration gradient and so it allows the diffusional process to occur much faster. In other words, reaction accelerates mass transfer rates in the liquid (roughly in proportion to the square root of the reaction rate constant). But if the reaction is too slow, as it is in the case of CO₂ hydrolysis, there is no mass transfer enhancement, although the solvent's capacity is still enormously high. What are the implications of this for MDEA as a solvent specifically for CO₂ removal?

For those who think in terms of theoretical stages, the chemical solubility is used as the basis for stepping off the number of theoretical stages, whether this is done on a piece of paper or within a computer simulation. The problem comes in translating the resulting NTS count into actual trays or bed depths for packing. The solvent capacity is extremely high, but the driving force for absorption is just as extremely low because of the poor physical solubility. The result is extraordinarily low tray efficiencies and enormous height equivalent to theoretical plate (HETP) and height of transfer unit (HTU) values.

The theoretical stage approach to simulation of such a process is utterly inappropriate; the process is completely controlled by the slow absorption rates, not by chemical equilibrium. The only way to approach this type of problem is through a true mass and heat transfer rate-based simulation that is grounded in the real physics and the real chemistry of the process. ProTreat is the only such simulator commercially available that is robust enough for general everyday use in amine treating.

MDEA was originally intended as a highly selective solvent for H₂S removal and for the maximum rejection of CO₂ into the treated gas stream. The reason it works so well in selective treating is that it does not react appreciably with CO₂, so it absorbs this gas only very slowly. It is not an exaggeration to state that it was never intended for use specifically in CO₂ removal. This is not to say that it can never find use in such an application, but the circumstances will be unique and limited. If MDEA is selected for a CO₂ removal application, it must be borne in mind that equilibrium-stage models tend to be quite optimistic in their predictions of CO₂ removal with MDEA.

The remainder of this article presents two case studies intended to demonstrate how MDEA in CO₂-only applications can fail, despite the designs having been done in strict accordance with a modified equilibrium-stage simulation: how ProTreat's mass and heat transfer model produces the correct design results; and how a bad design can be remedied with speciality solvents. Both case studies involve the removal of CO₂ from one gas stream, followed by blending the treated gas into another, higher CO₂ stream to produce final pipeline gas.

Case study 1

A plant for treating a stream of 9.5% CO₂ in methane with 50 wt% generic MDEA to a target level of 0.5% was initially designed according to the dictates of a commercial, reaction-modified, equilibrium-stage-based

simulator, which suggested that 22 trays would be adequate (see Figure 2 for a PFD of the plant). The treated gas was to be blended with other streams to meet a pipeline specification of 2% CO₂. Equipment was ready to be installed and the plant was scheduled for startup when Ineos was asked to validate the MDEA design. An evaluation using mass transfer rate-based simulations showed that the plant would be unable to meet even the 2% CO₂ specification required for the final blended gas, much less the 0.5% CO₂ target for the treated gas itself. Indeed, 50 trays would be needed to reach 0.5% CO₂ in the outlet gas using MDEA. Table 1 shows the results of equilibrium-stage-based calculations (seven stages, three trays each) and ProTreat simulations of the design case with 2 inch and 5 inch (50mm and 125mm) weirs. Clearly, mass transfer rate-based modelling indicates that even making 2% CO₂ in the treated gas with the original 2 inch (50mm) weirs is highly problematic.

The results of this assessment were certainly not what the engineers had expected and they were left scrambling for a solution. Fortunately, two circumstances provided a reprieve. First, the plant was expected to start up at lower rates and at a lower CO₂ level than was initially anticipated. Second, the gas processing facility had the flexibility to blend the treated gas with another gas stream from a diglycolamine (DGA) unit that was much lower in CO₂. Thus, even if the MDEA plant did not remove enough CO₂, the blended stream would still meet the treating requirement of 2% CO₂ in the pipeline gas. As a result, the engineers decided to proceed with the project using MDEA. As a precautionary measure, however, they were advised to increase the weir height in the contactor from 2–5 inch. The recommendation was also made to switch from MDEA to a Gas/Spec CS-2000 series solvent as the plant approached full design rates in the future. These solvents will remove much more CO₂ than generic MDEA.

An interesting aside is to enquire about the possible effects of operating with a colder lean solvent and the effect of replacing the 22 trays with, say, 50ft (15m) of packing. With a 5 inch (125mm) weir, lean temperatures of 80°F and 60°F would produce a treated gas containing only 0.97 mol% and 0.57 mol% CO₂, respectively, which would almost meet the target composition at full rates. Using 50ft (15m) of Mellapak Plus M252. Y packing with a 60°F (15.6°C) lean amine would produce gas containing 0.96 mol% CO₂. This indicates that structured packing is probably preferred if CO₂ slip is desired because its mass transfer characteristics are less conducive to CO₂ absorption.

Comparison of actual vs simulated plant performance at reduced-rate startup conditions

| | Measured performance after startup (Aug 2007) | ProTreat simulation |
|---|---|---------------------|
| Inlet gas flow, MMscfd (Nm ³ /s) | 6.4 (2.1) | 6.4 (2.1) |
| Inlet pressure, psig (barg) | 820 (56.5) | 820 (56.5) |
| Inlet temperature, °F (°C) | 81 (27) | 81 (27) |
| Inlet CO ₂ , mol% | 7.95 | 7.95 |
| Outlet CO ₂ , mol% | 0.8 | 0.7 |
| MDEA strength, wt% | 50 | 50 |
| Lean amine, USgpm (m ³ /h) | 100 (22.7) | 100 (22.7) |
| Lean loading, mol/mol | N/A | 0.0040 |
| Lean temperature, °F (°C) | 101 (38) | 101 (38) |
| Rich loading, mol/mol | N/A | 0.22 |

Table 2

As anticipated, at a lower gas rate (6.4 vs 10 MMscfd) and a reduced CO₂ concentration in the feed gas (7.95% vs 9.5%) the plant was able to operate for a number of months without serious difficulty. Table 2 shows the measured plant performance shortly after startup and compares it with ProTreat simulation. Even with reduced inlet CO₂ and gas flow, the plant was only able to remove CO₂ to 0.8 mol%, significantly higher than the 0.5 mol% thought to be achievable by a modified equilibrium-stage simulation of the original design case. The treated gas composition, in contrast, was fairly well predicted by ProTreat. Note that the lean amine loading was not measured; however, the regenerator was also simulated using the heat and mass transfer rate model and known regenerator dimensions and measured reboiler duty, and the lean loading was predicted to be 0.004 mol/mol, typical of what is commonly found in MDEA plants.

After two years of operation, the raw gas flow rate and its CO₂ content had finally risen to levels that demanded further action. The measured performance at that time (August 2008) is compared with simulation in Table 3. It is worth mentioning that although the plant was designed for a 130 USgpm (30 m³/h) circulation rate, the operators

were never able to exceed 100 USgpm (23 m³/h). Note also that the gas flow rate to the unit is still 10% below the design rate, and the CO₂ content is still 1.5 mol% lower than originally anticipated. Even under these conditions, reaching 0.5% CO₂ would require about 40 trays, not the 22 trays of the original design.

The situation took on greater urgency when the DGA unit shut down due to corrosion in the regeneration column. Without a blend gas to dilute the CO₂, the facility had to cut production. Notice that treated gas from the absorber itself is now close to the pipeline specification, so the facility is not able to blend any gas with this stream. By this time, the processor saw the need to implement the solvent change in order to assure maximum production.

The consequences of the incorrect original design were mitigated in part by a last-minute tray modification, and by the fact that the actual gas flow and composition were taken together over 30% lower than the design was supposed to accommodate. Only after two years of operation, when original design conditions must now be met, has the consequence of using a modified equilibrium-stage-based model for this type of application come to a head. The only sensible solution is a solvent

Comparison of measured and simulated performance near maximum capacity

| | Maximum rate (Aug 2008) | ProTreat simulation |
|---|-------------------------|---------------------|
| Inlet gas flow, MMscfd (Nm ³ /s) | 9 (2.95) | 9 (2.95) |
| Inlet pressure, psig (barg) | 830 (57.2) | 830 (57.2) |
| Inlet temperature, °F (°C) | 66 (18.9) | 66 (18.9) |
| Inlet CO ₂ , mol% | 8 | 8 |
| Outlet gas temp., °F (°C) | 114 (45.6) | 115 (46.1) |
| Outlet CO ₂ , mol% | 1.72 | 1.34 |
| MDEA strength, wt% | 52 | 52 |
| Lean amine, USgpm (m ³ /h) | 100 (22.7) | 100 (22.7) |
| Lean temperature, °F (°C) | 114 (45.6) | 114 (45.6) |
| Lean loading, mol/mol | N/A | 0.0044 |
| Rich loading, mol/mol | N/A | 0.287 |

Table 3

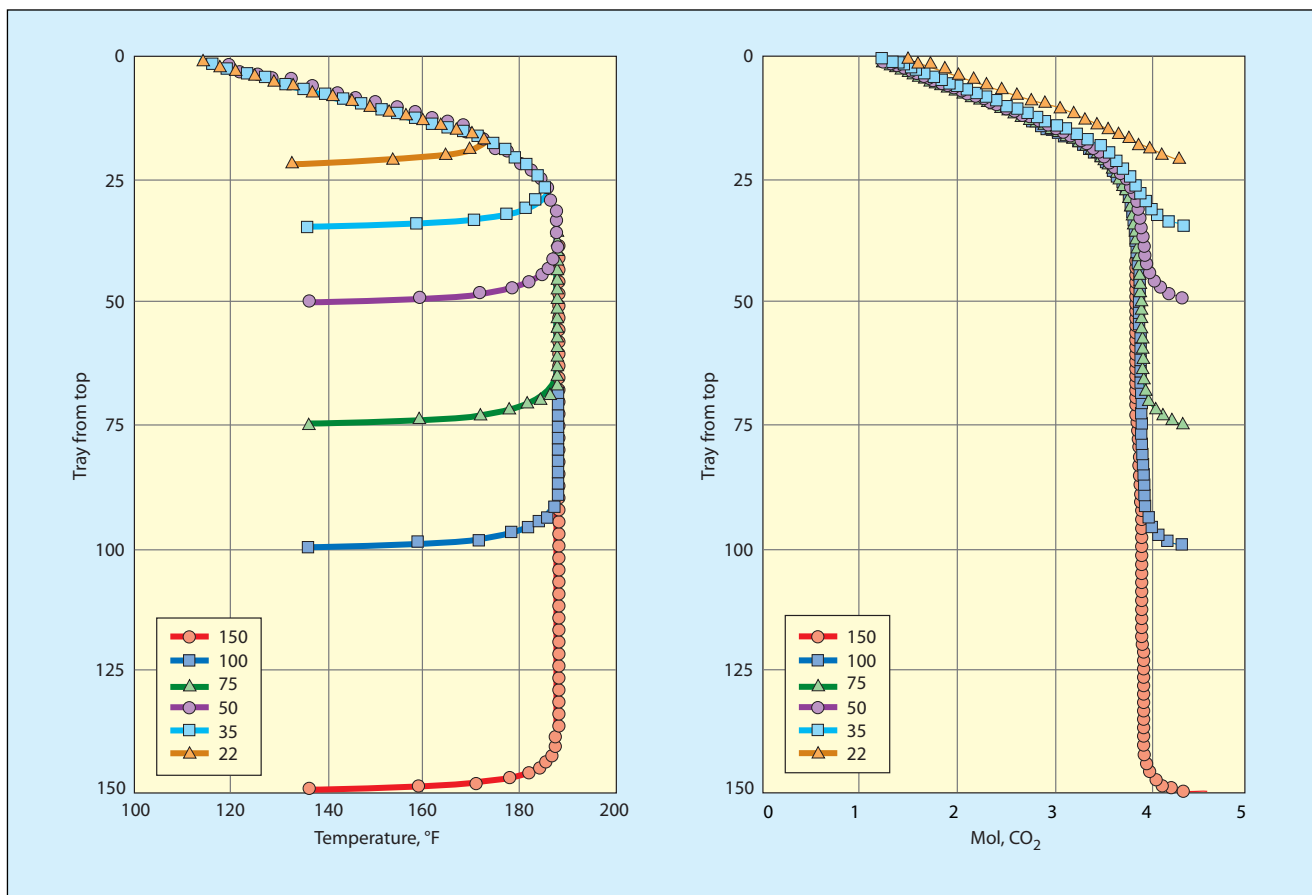

Figure 3 Plots of temperature and mol% CO₂ vs tray number for total tray counts from 22 (number actually installed) to 150. The absorber as designed can never achieve better than 1.3 mol% CO₂, not the <1 mol% intended

change-out to a speciality amine. Fortunately, ProTreat's mass transfer rate-based simulations allowed the operators of this facility to anticipate what was coming and to plan for corrective action well in advance. At the time of writing, the plant is in the process of being converted to a Gas/Spec CS-2000 series solvent.

Case study 2

This is another example of a natural gas containing CO₂ as the only acidic component. In this case, the processor needed to treat up to 177 MMscfd (58 Nm³/s) of gas with up to 4.5% CO₂. Treated gas from the absorber was to be blended with other gas streams to produce a total of 280 MMscfd (92 Nm³/s) of natural gas with a maximum 2 mol% CO₂ specification. It was therefore advantageous to have the amine plant remove as much CO₂ as possible because more of the untreated streams could then be blended with the treated gas to increase the facility's overall production rate. The design was based on the use of generic MDEA to remove greater than 600 lbmol/h (272 kmol/h) of CO₂ (see Table 4). Typically, plant operators like to target less than 1 mol% CO₂ in the outlet gas to achieve this kind of blending goal. (Treating 177 MMscfd from 4.0 mol% to 1 mol% CO₂ is a removal rate of 600 lbmol/h.) This target was thought achievable based on

results from prior modified equilibrium-stage-based simulations. However, mass transfer rate-based modelling predicts that the best this design could do is 1.19 mol% CO₂ even with 100 trays; 1 mol% is not achievable, although 650 lbmol/hr (295 kmol/h) removal is.

Interestingly, under the design operating conditions, this column is severely pinched in the middle, not at either of the ends. This is shown in Figure 3, where the temperature profile and the profile of mole percentage CO₂ in the gas are plotted as functions of tray number for total tray counts ranging from 22 (the number actually

installed) up to 150. These plots show that no matter how many trays are installed, the design target of <1 mol% CO₂ could never be achieved. As more trays are added, the temperature bulge simply expands to occupy the additional trays.

For several years after startup, the plant operated at lower rates because the feed gas was limited and the plant was continually experiencing foaming problems caused by the ingress of heavy hydrocarbons (C₆+) and pipeline treating chemicals such as H₂S scavengers. The foaming problem seemed to be exacerbated by the higher circulation rate required with MDEA when used for high CO₂ removal applications. Although foaming was addressed by modifying the filter-coalescer and eliminating the contamination source (by moving the H₂S scavenger injection point from upstream of the amine plant to downstream), the MDEA solution never removed as much CO₂ as the plant's operators had hoped. Table 5 shows a few measured data points of the actual removal with 50 wt% MDEA and compares them with ProTreat simulations. ProTreat appears to slightly under-predict the actual removal rate of CO₂ for Data set 2, although agreement is quite close for the other two cases, with predictions lying slightly above and slightly below measured data.

Design basis for case study 2

| | Design basis |
|---|--------------|
| Inlet gas flow, MMscfd (Nm ³ /s) | 177 (58) |
| Inlet pressure, psia (bara) | 1050 (71.5) |
| Inlet temperature, °F (°C) | 90 (32) |
| Inlet CO ₂ , mol% | 4.5 |
| Outlet CO ₂ target, mol% | <1 |
| Blended outlet CO ₂ , mol% | <2 |
| MDEA strength, wt% | 50 |
| Lean amine, USgpm (m ³ /h) | 900 (204) |
| Lean temperature, °F (°C) | 110 (43) |
| Lean loading, mol/mol | 0.005 |
| Rich loading, mol/mol | 0.3 |
| CO ₂ removal, lbmol/h (kmol/h) | >600 (>272) |

Table 4

Increasing demand for natural gas slowly pushed the rate to the design capacity, and five years after startup the plant could no longer meet the CO₂ specification while operating at a high gas throughput. At maximum gas throughput and circulation rate, the treated gas contained 1.4 mol% CO₂ (vs 1.3 mol% via ProTreat simulation) and the amount of gas that could be blended became severely limited. The processor was forced to negotiate a gas quality waiver with the pipeline company and other parties, allowing it to supply gas at the higher CO₂ level of 3 mol%. Only by paying a substantial penalty fee for this waiver could the processor continue to supply gas to meet the growing demand.

While plant personnel were struggling to maximise plant capacity, the plant engineers and managers were considering several longer-term options to address the problem. One possibility was to add another amine train to the facility. Another was to change the solvent to one more suited to deeper CO₂ removal. The processor contacted Ineos Oxide, which recommended Gas/Spec CS-2000 solvent for this particular application. Once the decision was made to proceed and the chemicals were brought on-site, by adding the solvent package to the existing MDEA solution, the conversion to the new solvent took only 12 hours to complete. The outlet CO₂ dropped from nearly 1.5 mol% to a few hundred ppmv. Table 6 shows measured performance data and comparisons with ProTreat simulations.

The deeper removal achieved with Gas/Spec CS-2000 translated into a CO₂ removal rate of 720 lbmol/h (326 kmol/h), which is a 20% increase in CO₂ removal capacity over generic MDEA. As a result, less gas now needs to be treated in the absorber and more gas can be bypassed, giving a substantial overall increase in total plant production without the need to suffer penalties from a waiver of the gas quality standard.

Other benefits from the conversion were improved plant reliability and reduced amine consumption. Since the solvent was removing more CO₂ from the gas at a lower solvent rate, the absorber operated more stably because of fewer foaming episodes. Figure 4 gives a trend of the pressure fluctuations of the absorber with MDEA and with Gas/Spec CS-2000 over a period of 12 days. The magnitude of the pressure fluctuations was reduced after the conversion (these pressures were measured after the filter changes were made). By improving the filtration equipment and improving the stability of the absorber operations, the plant was able to reduce its annual amine consumption by 73%.

Operating data and ProTreat simulations with MDEA at various inlet gas rates

| | Design goal | Data set 1 | Data set 2 | Data set 3 |
|---|-------------|-------------|-------------|-------------|
| Inlet gas flow, MMscfd (Nm ³ /s) | 177 (58) | 123 (40) | 154 (50.5) | 177 (58) |
| Inlet pressure, psia (bara) | 1050 (71.5) | 1126 (76.7) | 1025 (69.8) | 1050 (71.5) |
| Inlet temperature, °F (°C) | 91 (32.7) | 111 (43.9) | 97 (36) | 97 (36) |
| Inlet CO ₂ , mol% | 4.5 | 4 | 4.23 | 4.3 |
| Outlet CO ₂ , mol% | <1.0 | 1.3 | 0.87 | 1.4 |
| Outlet CO ₂ ProTreat, mol% | 1.6 | 1.44 | 1.13 | 1.30 |
| MDEA strength, wt% | 50 | 50 | 50 | 50 |
| Lean amine, USgpm (m ³ /h) | 900 (204) | 600 (136) | 841 (191) | 900 (204) |
| Lean temperature °F (°C) | 110 (43) | 124 (51) | 106 (41) | 106 (41) |
| Lean loading, mol/mol | 0.005 | 0.004 | 0.005 | 0.005 |
| CO ₂ removal, lbmol/h (kmol/h) | >600 (>272) | 372 (169) | 572 (259) | 570 (259) |
| Simulated removal, lbmol/h (kmol/h) | 570 (259) | 350 (159) | 528 (239) | 589 (267) |

Table 5

Operating data with Gas/Spec CS-2000 and comparison with ProTreat simulation

| | Design target | Data set 4 | Data set 5 |
|--|---------------|------------|------------|
| Inlet gas flow, MMscfd (Nm ³ /s) | 177 (58) | 152 (50) | 152 (50) |
| Inlet pressure, psia (bara) | – | 1014 (69) | 988 (67.3) |
| Inlet temperature, °F (°C) | – | 91 (32.8) | 85 (29.4) |
| Inlet CO ₂ , mol% | 4.5 | 4.3 | 4.37 |
| Estimated outlet CO ₂ , ppmv [§] | <1.0% | <100 | <200 |
| Simulated outlet CO ₂ , ppmv | – | 337 | 345 |
| Solvent strength, wt% | – | 48 | 48 |
| Lean amine, USgpm (m ³ /h) | – | 860 (195) | 871 (197) |
| Lean temperature °F (°C) | – | – | 100 (37.8) |
| Lean loading, mol/mol | – | 0.005 | 0.022 |
| CO ₂ removal, lbmol/h (kmol/h) | >600 (>272) | 720 (326) | 720 (326) |
| Simulated removal, lbmol/h (kmol/h) | – | 711 (322) | 723 ((327) |

§ Detectable limit ≅ 100 ppmv

Table 6

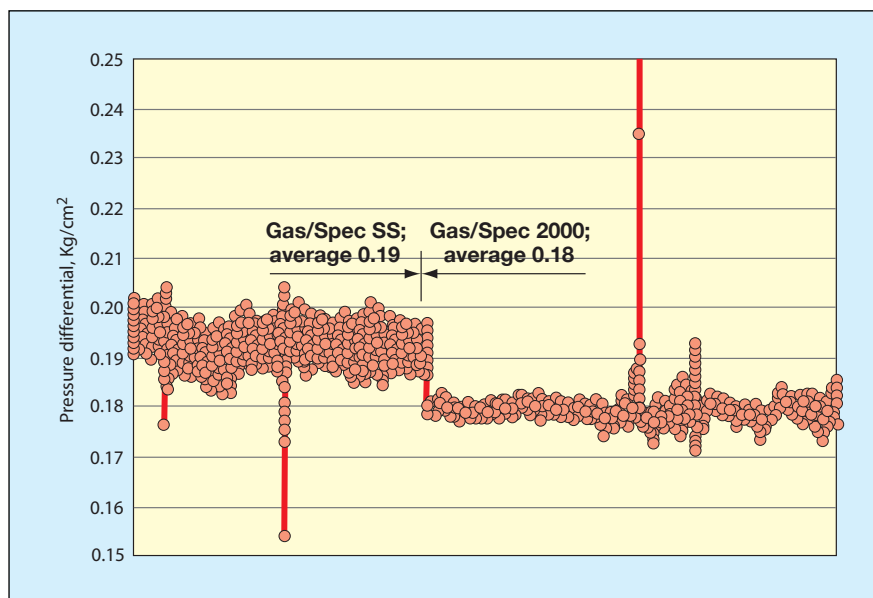

Figure 4 Absorber differential pressure with MDEA and with Gas/Spec CS-2000

Conclusions

Both cases outlined in this article demonstrate some of the limitations of using MDEA as a CO₂ removal agent. While MDEA is an excellent solvent for many treating applications requiring selectivity, it is not the most suitable solvent where moderate to high CO₂

removal is required. As a result of an overly optimistic model, the end processor had to deal with the costs of penalty fees and lost production from assets that did not live up to their original design simulations for years before the problem could be fixed.

There are numerous CO₂ removal

applications in which generic MDEA will work quite well. However, you must be careful not to ask for unrealistic removal rates and to view with suspicion performance predictions based on equilibrium-stage simulations, regardless of claims with respect to corrections for reaction kinetics. MDEA is a unique amine from the standpoint of CO₂ removal; its ultimate capacity is high and its very slow pseudo-reactivity with CO₂ means its regeneration energy requirements are low. However, it absorbs CO₂ only very slowly compared with reactive amines such as monoethanol amine (MEA) and diethanolamine (DEA). MDEA's principle benefit is slipping CO₂. It was never intended to be used for deep CO₂ removal and, as shown by the case studies reported here, even some bulk removal applications are problematic.

On the one hand, the (chemical) equilibrium capacity of MDEA for CO₂ is very high, approaching one mole per mole at high CO₂ partial pressures. On the other, the physical solubility driving force for absorption, which relates to the Henry's Law solubility of CO₂ in essentially water, is so small that absorption is too slow for trays to have anything like reasonable efficiencies. Consequently, the translation from the few ideal stages calculated theoretically to the number of real trays actually

necessary becomes extremely hard to make with any degree of reliability.

These case studies demonstrate that designs based on theoretical stages, with or without kinetics corrections, can be very optimistic, so much so that, when built, the plants completely fail to meet expectations. In the present cases, the failures were mitigated by such factors as initial operation at lower than design loads and willingness to accept penalties for feeding below-specification gas into a pipeline. This gave enough time to make such adjustments as a complete change of solvent to meet design conditions when they actually occur. Such reprieves, however, are not always given and when they are not the plant's owners are left desperately searching for a solution. Usually, the solution is more expensive, whether it is extra tower height for mass transfer contacting or a speciality amine that should have been specified in the first place. As shown in Case 2, the speciality solvent Gas/Spec CS-2000 was easily able to get to parts-per-million CO₂ levels and simulation matched performance.

These kinds of problems can be avoided by using the mass and heat transfer rate-based simulator ProTreat to model the process correctly. One of the beauties of such simulations is that they use real trays and actual depths of real packings from the outset. Furthermore,

they take proper account of the driving forces for absorption and regeneration and they predict the separations achieved by real equipment containing actual internals with a superb degree of reliability. The internals details are not used just to calculate pressure drop and flood characteristics; internals details are used primarily to determine mass transfer performance.

Accurate simulation can provide increased ability to anticipate the effect of changing treating conditions in the plant. The problems discussed in the case studies could have been avoided by selecting the correct solvent for the application at the outset, or by better prediction of when a solvent change is needed.

ProTreat is a mark of Optimized Gas Treating. DGA is a mark of Huntsman Corporation. GAS/SPEC and CS-2000 are trademarks of Ineos Oxide, a division of Ineos Americas. Mellapak Plus M252.Y is a mark of Sulzer Chemtech.

Jenny Seagraves is Senior Research & Development Leader with the Ineos Gas/Spec Technology Group of Ineos Oxide, a division of Ineos Americas, E Setauket, New York. Email jenny.seagraves@ineos.com

Ralph H Weiland is a co-founder of Optimized Gas Treating, Clarita, Oklahoma. Email: ralph.weiland@ogtrt.com
