

New Strategies for Acid Gas Enrichment¹

Ralph H. Weiland
Optimized Gas Treating, Inc.
Clarita, OK 74535, USA
ralph.weiland@ogtrt.com

Tofik K. Khanmamedov
TKK Company
Sugar Land/Houston, TX 77478, USA
tofik_khanmamedov@tkkcompany.com

ABSTRACT

Sulphur plant performance and capacity are greatly affected by feed gas quality. Thus, increasing the H₂S content of Claus plant feeds is needed when plant throughput is limited or the sour gas has too low an H₂S:CO₂ ratio for producing satisfactory acid-gas. The key to acid gas enrichment (AGE) is selectivity, and of the generic amines, *N*-methyldiethanolamine (MDEA) is the most selective. The FLEXSORB® family of hindered amines is even more selective; however, these solvent are more expensive than generics.

Recently, a new patented family of HIGHSULF™ amine-based desulphurization technologies and strategies was introduced in the literature. Among other applications, the HIGHSULF technology enhances the well-known SCOT or similar processes, uses identical equipment, requires almost no additional capital investment, and produces extremely high quality Claus feed with generic MDEA, or MDEA spiked with promoters. The beauty of HIGHSULF is its simplicity—any existing AGE or SCOT unit can be switched easily to HIGHSULF and back to conventional treating without shutdown.

This paper uses the ProTreat™ process simulator to substantiate the technology and to discuss several cases of both the original and extended HIGHSULF process strategies. Attention focuses on using HIGHSULF with MDEA solvents to upgrade low-quality SRU feed and to produce high H₂S gas from the SRU's TGTU amine section. FLEXSORB or other special solvent performance can be had using HIGHSULF with generic MDEA.

1. INTRODUCTION

Many sour gases contain small enough concentrations of H₂S to pose challenges because the acid gas produced in the treating plant is sub-quality for Claus sulphur plant feed, but can be neither vented nor incinerated. Even in plants with a moderate CO₂:H₂S ratio of say 4:1, if complete acid gas removal is necessary (LNG for example), using a single contactor will necessarily produce an acid gas stream containing only 20% H₂S.

¹ Paper presented at SOGAT 2011, Abu Dhabi, UAE, March, 2011

In other situations, if a significant proportion of the CO₂ must be removed with the H₂S, the resulting Claus plant feed may be too dilute for a conventional Claus plant.

As shown by the contour map of Figure 1, sulfur plants are most efficiently operated when the feed contains 55% or more H₂S. The balance of the SRU feed is CO₂ and water, possibly with small amounts of hydrocarbons or other components. Lower concentrations of H₂S result in greater sulphur plant complexity, larger equipment, and higher cost. Streams having less than 32% or so H₂S are near the lower limit for a straight-through Claus process. Such streams cry out for enrichment.

HIGHSULF is a general, patented, process strategy that can be applied incrementally in amine treating plants to increase the H₂S concentration in the acid gas from the regenerator and produce an increasingly high quality Claus sulphur plant feed. HIGHSULF technology recognizes that the higher the H₂S content of the gas being treated in an amine unit, the greater will be the H₂S concentration in the acid gas from its regenerator. HIGHSULF processing actually takes steps to increase the H₂S content of the feed gas to the amine plant itself. As a result, the family of HIGHSULF processes produces a more concentrated product stream, as discussed by Khanmamedov¹⁻⁸. One such application is upgrading the acid gas from the main amine plant regenerator to higher H₂S content by processing the regenerator acid gas in another, smaller amine plant. This is termed acid gas enrichment (AGE). It is almost always the case that this secondary treating or AGE unit can very profitably apply HIGHSULF technology.

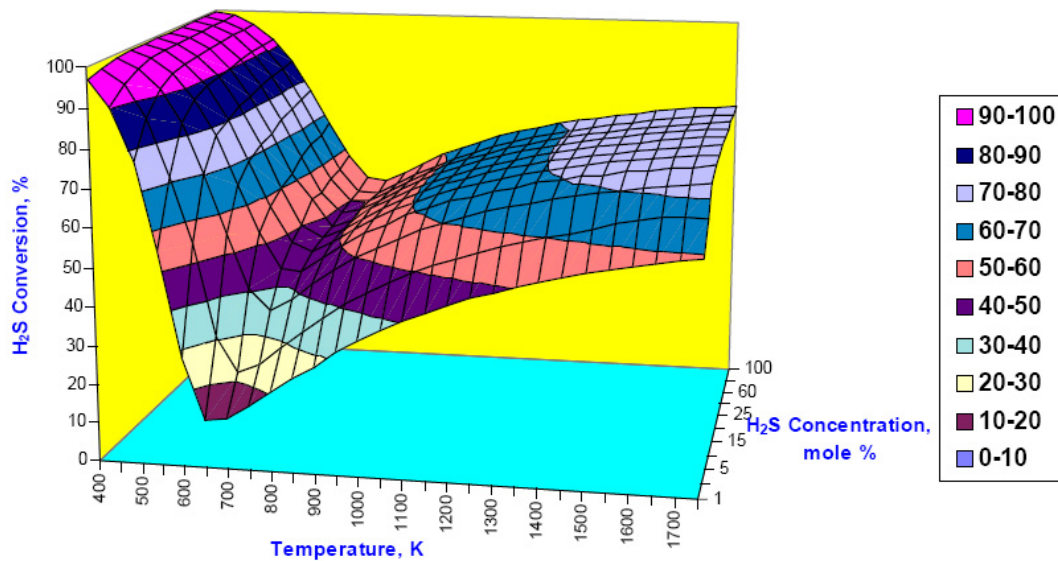

Figure 1 Equilibrium Conversion of Hydrogen Sulphide to Sulphur in the Claus Process. Conversion versus Temperature and Concentration

Within the overall HIGHSULF strategy, there are numerous flowsheet configurations that can be applied to AGE. This paper examines several possible processing schemes applied to the enrichment of very low (8%) H₂S-content gas and of marginally processable gas (34% H₂S).

2. THE VITAL ROLE OF SELECTIVITY

AGE depends critically on maximizing process selectivity for preferential absorption of H₂S and for simultaneous rejection of CO₂. Achieving the highest possible selectivity for H₂S over CO₂ starts by using the right solvent under the right process conditions in the right equipment. Attention to all three of these factors is paramount to the successful process selection, design, and operation of AGE units. The perfect AGE process would remove *all* the H₂S and *none* of the CO₂, thereby feeding the Claus plant with pure wet H₂S. Such a process would have perfect selectivity. Detailed discussions of selectivity have been presented in many places including Khanmamedov³⁻⁴, Weiland et al.^{13,14,16}, and Khanmamedov and Weiland⁹ so only a brief review is given here.

The equilibrium solubilities of H₂S and CO₂ in selective solvents such as methyldiethanolamine (MDEA) do not differ radically from each other; in other words, chemical solvents in and of themselves do not have great inherent thermodynamic selectivity. In the final analysis, selectivity is completely determined by the difference in absorption *rate* between H₂S and CO₂, and absorption rates are really controlled by (1) reaction kinetics and (2) the hydraulic and mass transfer characteristics of the contacting equipment (as expressed by the relative magnitudes of gas- and liquid-side mass transfer coefficients). Most practitioners are so fixated on equilibrium-stage concepts, empirical tray efficiencies and empirical packing HETPs, the very fact that the mass transfer characteristics of the contacting equipment sets efficiencies and HETPs is largely overlooked. Consequently, there is also a generally poor understanding of separation equipment from the perspective of inherent mass transfer characteristics and how they are affected by equipment geometry and process conditions. Even the effect of reaction kinetics has been misinterpreted and misapplied to what are inherently equilibrium stage models¹⁵ in a misguided attempt to incorporate reaction kinetics.

MDEA is the most commonly used amine in selective treating. It reacts with H₂S and CO₂ at chemical rates that are at opposite ends of the spectrum. H₂S absorption is accompanied by an *instantaneous* proton transfer reaction associated with H₂S dissociation and amine protonation. On the other hand, MDEA is non-reactive with CO₂, and CO₂ reacts only *very slowly* with water to form bicarbonate ion—amine carbamate is not formed. Thus, from a purely reaction kinetic perspective, MDEA is itself highly selective for H₂S.

As devices for carrying out separations, trays and packing (both random and structured) behave quite differently, both hydraulically and in terms of inter-phase contact. The most obvious reason for this difference is that trays usually have a continuous liquid phase and dispersed gas phase. The opposite is almost always true of packing, with liquid film flows that are relatively quiescent compared to the highly agitated state of the liquid flowing across trays. Vapour flows are quite turbulent for both trays and packing. Consequently, it is only to be expected that these types of equipment would have different mass transfer characteristics. These differences are decisive in selectivity because the mass-transfer resistance to H₂S absorption is primarily in the gas phase, while for CO₂ it is in the liquid phase. Thus the degree of selectivity can be controlled somewhat by choosing the relative resistances to mass transfer offered by the two phases through the judicious selection of tower internals and reaction kinetics. Phase resistances are functions of (1) the type (trays, random packing, structured packing) and (2) mechanical details (tray passes, weir heights, packing brand, size, crimp angle, etc.)

of the contacting equipment itself as well as (3) the way the equipment is operated hydraulically (flow rates and phase properties that depend on temperature and pressure) and (4) how reaction kinetics affects mass transfer in the liquid. AGE processes are *completely* dependent on relative rates of mass transfer. Only a true heat- and mass-transfer-rate based model such as ProTreat deals directly with the mass transfer characteristics of equipment and correctly applies chemical reaction kinetics to the calculations. Thus, only ProTreat stands a realistic chance of reliably *predicting* performance in a specific piece of equipment. Reliable simulations can be done only if the simulation tool itself is cognizant of the mass transfer behaviour of the internals. The engineer doing the calculations must also keep in mind the hydraulic regime in which the column is operating, e.g., spray versus froth regimes for trays as discussed by Weiland et al.¹⁵

To summarize, selectivity is a function of the reaction rate of CO₂ with the amine. Because CO₂ does not react with tertiary and sterically-hindered amines, these are the only amine-based solvents that make any sense in highly selective treating applications. Commercially, this makes them the only contenders in AGE, with MDEA (sometimes assisted by partial neutralization) and the hindered amines as the only realistic candidates. Because the hindered amines currently in commercial use are all members of the FLEXSORB[®] family and are proprietary to ExxonMobil Corporation, the remainder of this paper focuses on generic MDEA.

Two applications of HIGHSULF[™] are considered in what follows: (1) upgrading a marginally-processable Claus feed (34% H₂S) to super-high quality and (2) enriching a very low quality (8% H₂S) acid gas to quite acceptable quality. The purpose is to point out the advantages and disadvantages of several HIGHSULF schemes relative to each other and relative to a completely conventional AGE process flowsheet.

3. AGE FLOWSHEETS

The most common (and least effective) processing scheme for AGE is the conventional flowsheet shown in Figure 2. The low quality acid gas (H₂S, CO₂ and trace other components) is contacted with selective solvent in the low pressure AGE absorber. This is intended to recover most of the H₂S and reject as much of the CO₂ as possible. The shortcoming of this scheme is that the acid gas feed itself is fixed by upstream processing, whereas, if it could be made to contain more H₂S, the gas to the SRU would automatically be of higher quality.

The flowsheet shown in Figure 3 is the simplest implementation of the patented HIGHSULF process that permits controlling the effective composition of the AGE unit feed gas. The basic principle behind the HIGHSULF concept is quite simple: *the higher the H₂S content of the feed gas to the absorber, the higher will be its absorption rate into the solvent.* Concomitantly, higher H₂S in the feed means lower CO₂ content so the CO₂ will be absorbed more slowly. The result is faster H₂S absorption and slower CO₂ absorption, i.e., improved selectivity. The net result is that these two factors combine to produce a higher H₂S concentration in the acid gas from the regenerator. The source of the additional H₂S in the absorber feed gas is recycled regenerator acid gas, and the

greater the recycle flow the richer the absorber feed and, therefore, the richer the acid gas ultimately produced.

Depending on the extent to which the HIGHSULF technology is applied, the combined feed to the AGE absorber can be made fairly rich in H₂S, allowing an even richer SRU feed to be produced. An alternative scheme according to Palmer^{10,11} is shown in Figure 4 where the raw acid gas is made to enter the AGE absorber at an intermediate tray so that the bottom section of the absorber removes the bulk of the recycle H₂S before it joins the low quality acid gas feed.

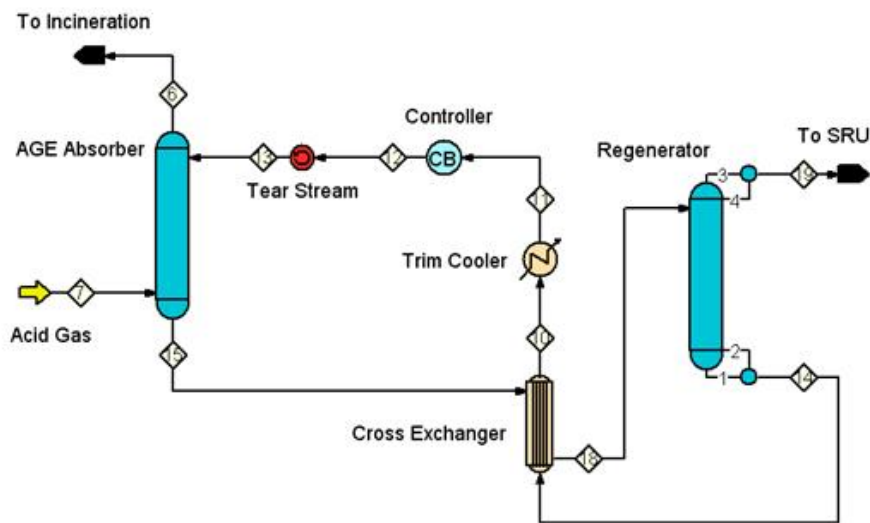

Figure 2 Conventional AGE Unit

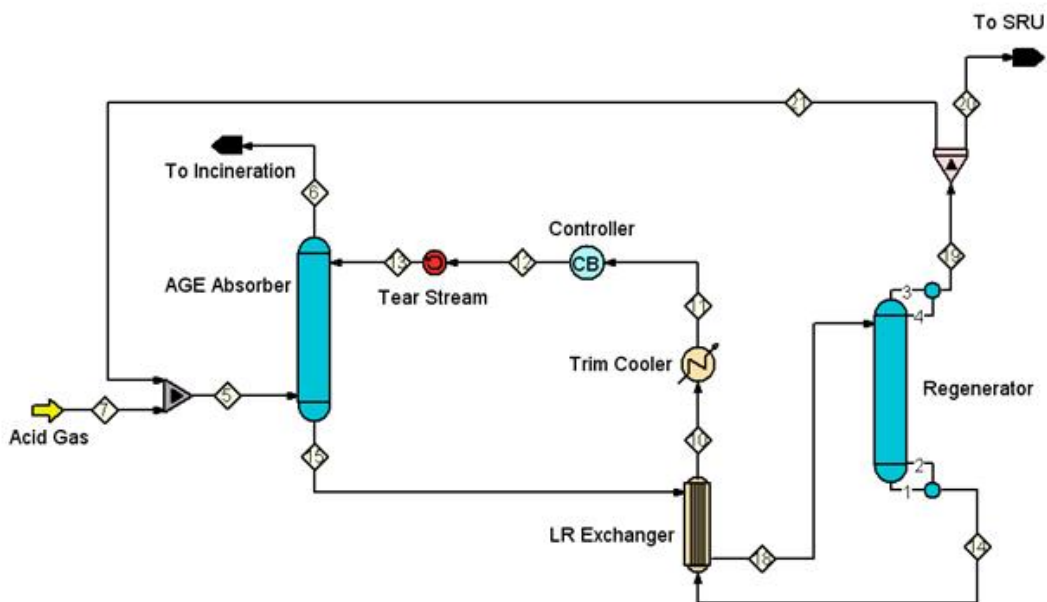

Figure 3 HIGHSULF with Combined Feeds

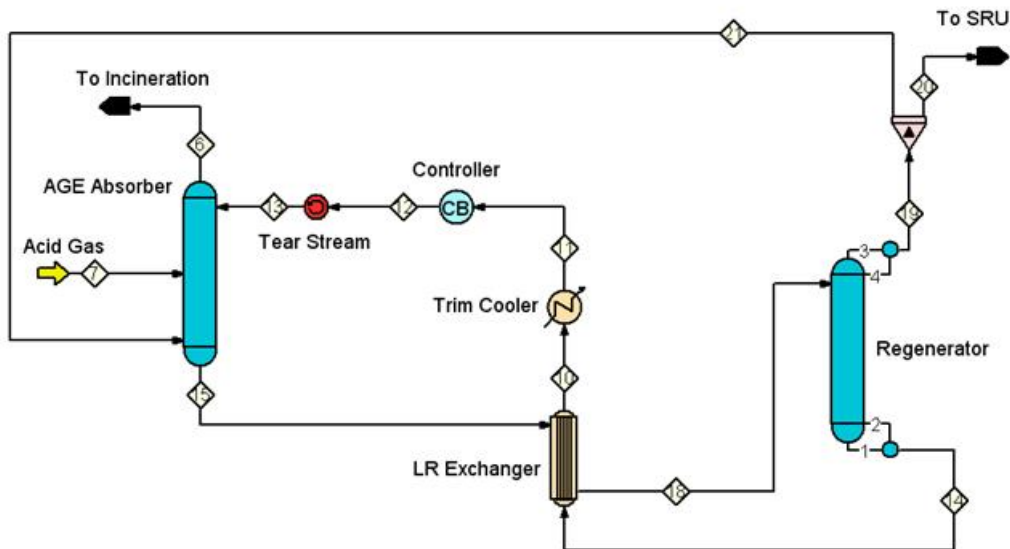

Figure 4 HIGHSULF with Separate Feeds

Mak et al.¹² proposed another set of processing schemes constructed around the notion of using two absorbers, as shown in Figure 5. However, in this approach, a separate column, that involves an additional and substantial capital investment, is used in an attempt to enrich the already rich SRU feed (AGE #1 in the figure). The weak acid gas is enriched in yet another separate operation (AGE #2). Thus no advantage is taken of the richer acid gas that could be fed to AGE #2 by admixing with a slipstream of SRU feed.

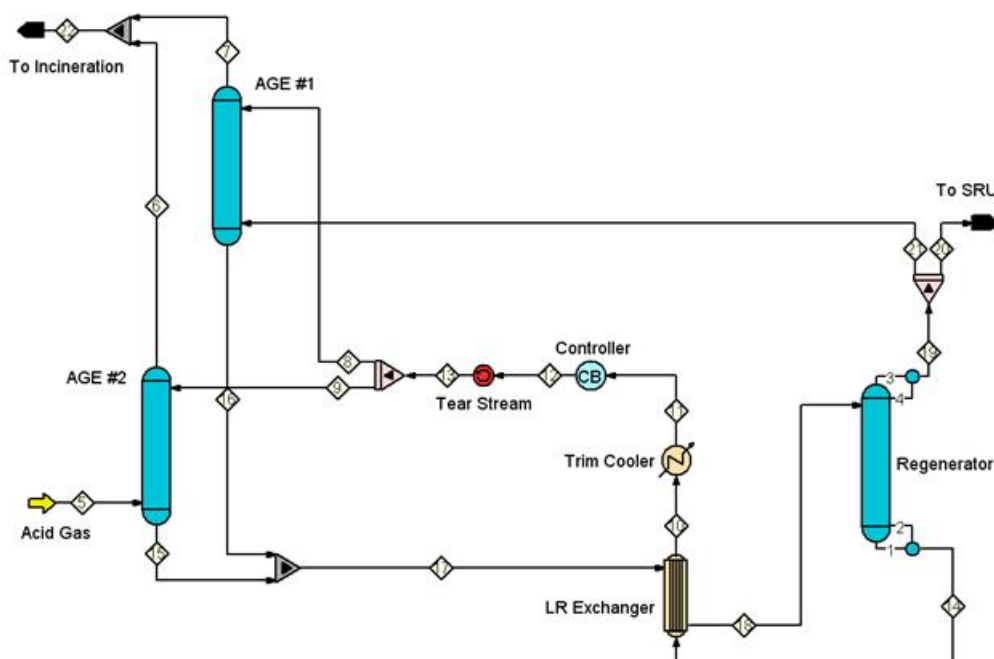

Figure 5 Processing with Two AGE Absorbers

4. ENRICHING MODERATE H₂S ACID GAS STREAMS

The 25 MMscfd acid gas stream coming from a main amine treating unit contains 34% H₂S, 64% CO₂ and 1% each of methane and ethane and is at 15 psig and 120°F. This is at the lower operability end of a straight-through sulphur plant and can be enriched considerably by treating with MDEA. The solvent used is 3,500 gpm of 45 wt% MDEA at 120°F. All absorbers contain 20 conventional valve trays and are sized for 70% flood. Regenerators contain 30 trays with 120°F condensers. Reboiler conditions are 15 psig and 275 MMBtu/hr duty. The main constraint on all operating schemes is that gas to incineration cannot exceed 75 ppmv H₂S. This is a somewhat arbitrary stipulation but it ensures that comparisons are done under the same requirements.

4.1. Conventional Amine Unit

The conventional scheme (Figure 2) sets the comparison standard. Under the stated conditions, the ProTreat™ simulator predicts that enrichment to 62% H₂S (wet basis) is possible, while sending only 40 ppmv H₂S to incineration. At 20 trays, the absorber appears to be over-trayed. This means the H₂S leak is controlled principally by amine lean loading, which is a direct function of reboiler duty but, more importantly, the extra trays are removing CO₂ and diluting the SRU feed gas. When run with 10 trays in the AGE absorber, simulation indicates 73% H₂S in the SRU feed and 69 ppmv H₂S in the gas to incineration.

4.2. HIGHSULF with Combined Feeds

HIGHSULF technology endeavours to produce a better quality SRU feed by recycling part of the SRU feed itself to enhance the H₂S content of the plant's acid gas feed. In its simplest implementation, recycle gas is re-combined with raw feed. ProTreat simulation predicts that the quality of the SRU feed is a function of the extent of application of the HIGHSULF strategy. Figures 6(a) and (b) show how the degree of enrichment and the H₂S leak to the stack vary with increasing levels of application of HIGHSULF. As HIGHSULF is applied increasingly beyond 65%, the point is reached where H₂S leak

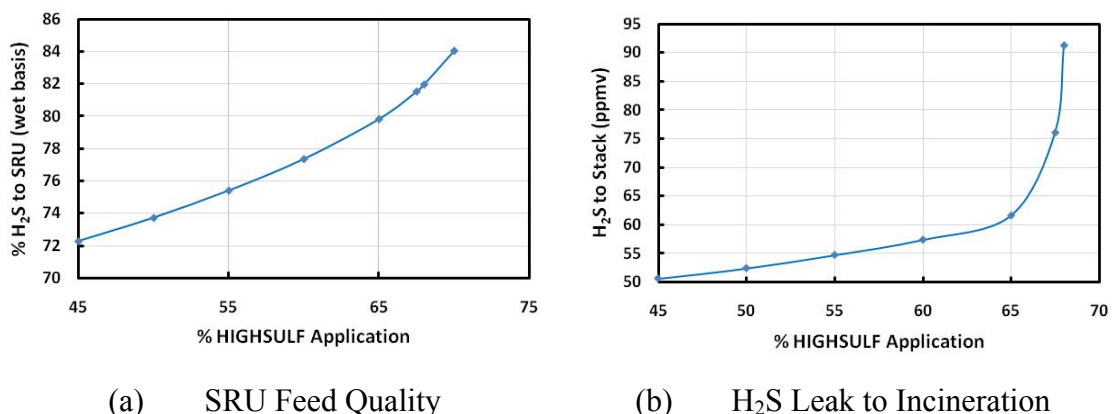
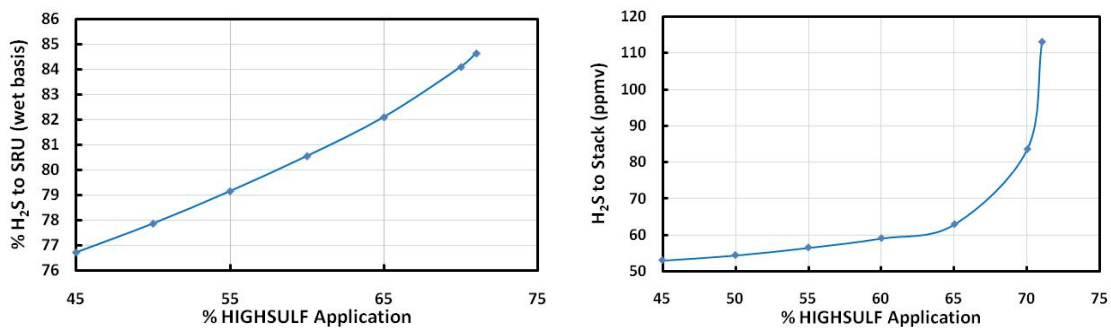

Figure 6 How AGE Unit Performance Improves with Application of HIGHSULF

to the stack suddenly escalates because the AGE absorber becomes overloaded and H₂S breaks through into the incinerator gas. However, by the time this happens, the wet SRU feed has reached nearly 82% H₂S! The best a conventional AGE unit could do under identical conditions of flow and energy usage was 72% H₂S. Obviously there is a limit to how vigorously HIGHSULF can be applied before the operation collapses. However, it is remarkable that when the optimal extent of HIGHSULF™ is applied, the SRU feed quality can be increased so much *for zero operating cost* that the dry gas now contains 87% H₂S and only 13% CO₂.

4.3. HIGHSULF with Separate Gas Feeds

The recycled gas is quite a bit higher in H₂S content than the original acid gas stream so the next logical step might be to send the recycle gas to the bottom of the AGE absorber and introduce the acid gas itself part way up the column. In this way the higher CO₂ content of the acid gas has less opportunity to be absorbed into the solvent and reduce its H₂S holding capacity. This kind of scheme corresponds to Figure 4. Preliminary ProTreat simulations showed that introducing the acid gas below tray 14 from the top in a 20-tray column was almost optimal from the standpoint of keeping the incinerator gas safely below the 75 ppmv maximum allowed. The simulated results plotted in Figure 6 correspond to acid gas feed below tray 14. There is scarcely any improvement of the two-feeds case over the common-feed setup. In this case, therefore, the addition of a second gas-feed nozzle and the associated complication of the special tray arrangement at the mid-tower feed point are not worth the trouble. The two flowsheets have equivalent performance, and both produce an extraordinarily high quality Claus feed.



(a) SRU Feed Quality

(b) H₂S Leak to Incineration

Figure 7 AGE Unit Performance Using HIGHSULF with Two Gas Streams. Sour Gas Feed Below Tray 14; SRU Gas Below Tray 20

4.4. Using Two AGE Absorbers

When two AGE absorbers are used, there is the question of how to split the common solvent flow from the regenerator between them. In the present case, this was done on the basis of equal ratio of solvent flow to H₂S flow in the entering gas streams. Figure 8 shows the effect of various extents of regenerator acid gas recycled to AGE Absorber #1 in Figure 5.

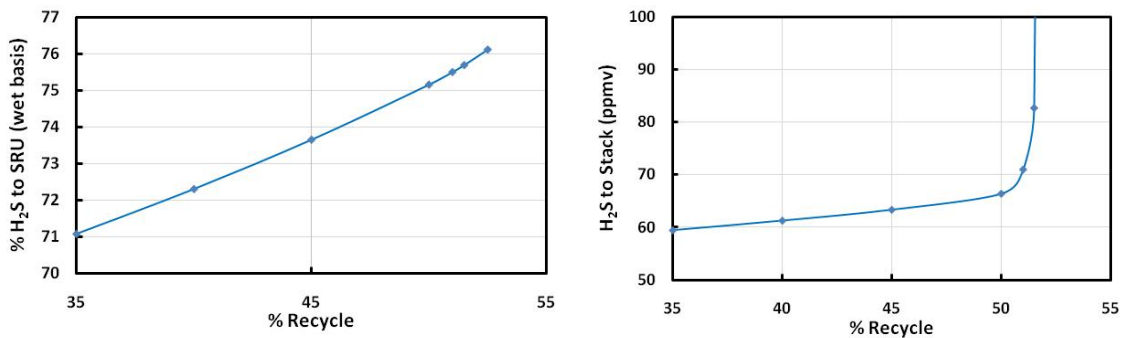

(a) SRU Feed Quality

(b) H₂S Leak to Incineration

Figure 8 AGE Unit Performance Using Two Separate AGE Absorbers

It is immediately evident that this flowsheeting scheme gives inferior processing to HIGHSULF™. The reason is that reliance for improved performance has been placed entirely on the recycle gas AGE unit. The acid gas AGE unit itself is still feeding on the original gas, not a gas whose H₂S content has been in any way enhanced, as it is in HIGHSULF. Therefore, no advantage is being taken of the effect of SRU gas recycle on performance of the acid gas AGE unit. The acid gas AGE unit goes sour because of H₂S breakthrough at only about 51% SRU gas recycle, and at that point, the plant itself is producing only about 75% H₂S in the SRU feed gas. This is still an improvement over conventional AGE, but falls well short of HIGHSULF processing.

5. ENRICHING LOW H₂S ACID GAS STREAMS

The acid gas flow is the same as in the high H₂S case, 25 MMscfd, but the H₂S content is only 8%, with CO₂ at 90% and methane and ethane making up 1% each. The solvent flow used for all simulations is 1250 gpm at 120°F. All other conditions are the same as for the high H₂S cases.

ProTreat™ simulation of a conventional AGE unit with 20 absorber trays suggests an SRU feed upgraded from 8% to 33.7% H₂S (dry basis); however, the absorber is over-trayed so it is picking up too much CO₂ and unnecessarily diluting the SRU feed with excess CO₂. When the same absorber contains only 10 trays, the 75 ppmv H₂S specification on the incinerator gas can still be met but the dry-basis H₂S content of the SRU feed rises to 47%, a satisfactory feed for a straight through Claus plant.

The maximum application of combined-feed HIGHSULF (Figure 3) consistent with meeting the 75 ppmv H₂S specification on incinerator gas is about 53%. This gives a dry-basis SRU feed of 54% H₂S, representing about a 15% improvement over a conventional AGE plant. As is the case with treating moderately-high H₂S gas, when HIGHSULF is over applied the AGE contactor becomes overloaded and breakthrough occurs. This causes rapid escalation of H₂S in the incinerator gas. However, a 15% improvement over conventional treating can be had for essentially zero operating expense and vanishingly-small capital cost (controller and duct work or pipe).

When the combined-feed HIGHSULF configuration is replaced with separate feeds (Figure 4) for acid gas and recycle gas, Figure 9 shows that acid gas feed below tray 14 is again close to optimal in terms of minimizing H₂S leak from the AGE absorber. With feed to tray 14 and HIGHSULF applied to the maximum extent of about 70%, the SRU dry-basis feed is simulated to contain nearly 71% H₂S. This is an improvement of more than 50% over the conventional AGE unit, and 30% over the combined-feed HIGHSULF configuration. The reasons for the significant improvement are two fold. Firstly, by injecting the original acid gas part way up the column, it is exposed to fewer contact trays, so less CO₂ is absorbed. As was seen for conventional AGE, only 10 contact trays are needed for optimal enrichment within the constraint of <75 ppmv H₂S leak. In the present case, the added H₂S demands a few more trays to meet the same requirement. Second, by removing the bulk of the H₂S on the lower six trays before it mixes with the dilute acid gas stream, the driving force for absorption is kept high and H₂S removal from the recycle gas is faster and more efficient. In essence, the SRU feed is enriched on the lower six trays and the original acid gas is upgraded on the top 14 trays, so in a single column tremendous enrichment can be achieved. The key is nevertheless acid gas recycle as taught by the HIGHSULF patents.

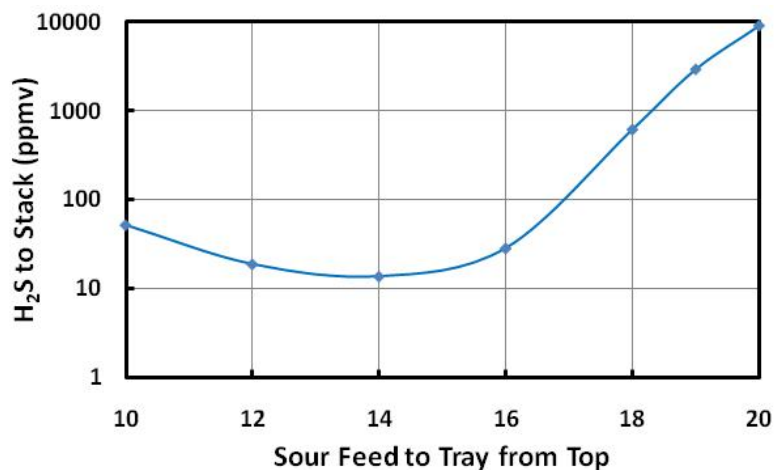

Figure 9 Effect of Acid-gas Feed-tray Location on H₂S Leak to Incineration

Turning finally to the two absorber configuration, because the same total solvent flow must now be divided between two separate AGE absorbers, it turns out that (1) the percentage of SRU gas that can be reprocessed for enrichment is more limited and (2) each AGE absorber requires the full 20 trays to met the <75 ppmv H₂S leak. The enriched SRU feed is only 47% H₂S, no better than a conventional AGE unit operated at maximum selectivity. The problem is the need to divide the solvent flow between the two absorbers and excessive CO₂ pickup in the acid gas treater as a result of it needing additional trays to remove H₂S at a reduced solvent rate.

6. TAIL GAS TREATING

The patented HIGHSULF strategy can be applied with equal success to the amine section of a tail gas treating unit^{17,18}. For, a conventional single absorber plus single regenerator operating on a 1.85% H₂S 22.6% CO₂ Claus tail gas was simulated¹⁸ to produce a 55% H₂S Claus feed and simultaneously slip only 135 ppmv H₂S to incineration. A combined feed HIGHSULF scheme (Figure 3) with 75% acid gas recycle was simulated to produce an 80% H₂S Claus feed while sending only 250 ppmv H₂S to incineration. In addition, the gas volume to the SRU would drop from 1495 m³/h to 1033 m³/h, considerably unloading the Claus plant. With a two-feed absorber (Figure 4) one can potentially achieve an 85% H₂S feed to the SRU with an H₂S leak of 280 ppmv H₂S to incineration. Similarly to the enrichment cases considered earlier, the benefit from having two feeds and the attendant potential problem of good vapour distribution beneath a mid-tower tray does not seem justified by the small increase in SRU feed quality. Thus, from the cases we have examined, the basic combined-feed HIGHSULF strategy appears to bring almost as much benefit as more complex schemes.

7. CONCLUDING REMARKS

It appears that applying patented HIGHSULF technology *always* leads to better AGE unit performance over a conventional AGE plant. Even if higher H₂S content is not required for good sulphur plant operation itself, eliminating CO₂ reduces the gas load on a sulphur plant, thereby increasing its capacity and the sulphur recovery level. HIGHSULF provides H₂S-rich feeds in a single step, thereby eliminating the need for separate enrichment. Astonishingly, there is almost no operating cost associated with applying HIGHSULF strategy. It is not a great oversimplification to say that nothing much more than a minor rerouting of piping is needed to achieve remarkable increases in SRU feed quality. Rarely is nature so gratuitous.

Because potentially the entire gas stream can be absorbed, an amine-based AGE unit is quite a severe test of one's ability to model selectivity. Gas flow and composition vary rapidly throughout the contactor, and concentration profiles can become inverted, even forming an H₂S bubble within the contactor. The key is mass-transfer rate-based modeling. By being able to simulate amine treating not just in terms of material balances but by analysing the columns as pieces of real equipment with mass transfer taking place within froths on actual trays and films flowing on real packed surfaces, the ProTreat™ simulator has demonstrated unequivocally the extraordinary effectiveness of HIGHSULF™ technology. It is a rare occasion that such enormous benefits can be had at negligible cost.

8. REFERENCES

1. Khanmamedov, T. K., U.S. Patent Number 5,556,606 September 17, 1996
2. Khanmamedov, T. K., U.S. Patent Number 5,718,872 February 17, 1998
3. Khanmamedov, T. K., U.S. Patent Number 5,716,587 February 10, 1998

4. Khanmamedov, T. K., NPRA Q&A Answer Book, V. *Energy & Environmental Management*, Atlanta, GA, p.14, 1998
5. Khanmamedov, T. K., National Meeting of A.C.S., San Diego, CA, 2000
6. Khanmamedov, T. K., U.S. Patent Number 6,506,349, January 14, 2003
7. Khanmamedov, T. K., Canada Patent Number 2,204,351 September 17, 2002
8. Khanmamedov, T. K., PCT/US1995/013768 October 26, 1995
9. Khanmamedov, T. K., Weiland, R. H., *Upgrading Acid Gas Streams*, Sulphur, September-October, 2008
10. Palmer, G., Canada Patent Number 2461952, September 25, 2005
11. Palmer, G., U.S. Patent Number 7,147,691, December 17, 2006
12. Mak, J., Nielsen, R. B., Chow, T., Morgan, O., Wong, V., US Patent Number 7,635,408, December 22 2009
13. Weiland, R. H., *Acid Gas Enrichment I: Maximizing Selectivity*, PTQ Gas, Spring, 2008a
14. Weiland, R. H., *Acid Gas Enrichment II: Maximizing Selectivity*, PTQ Gas, Spring, 2008b
15. Weiland, R. H., Hatcher, N. A., Nava, J. L., *Designing Trays for Selective Treating*, Distillation and Absorption 2010, Eindhoven, The Netherlands, 12–15 September, 2010.
16. Weiland, R. H., Sivasubramanian, M. S., Dingman, J. C., Laurence Reid Gas Conditioning Conference, Norman, OK, 2003.
17. Weiland, R. H., Khanmamedov, T. K., Acid Gas Enrichment Flow Sheet Selection, Sulphur, September-October, 2010
18. Khanmamedov, T. K., Weiland, R. H., *Top Treatment*, Hydrocarbon Engineering, December 2010.

ProTreat™ is a trademark of Optimized Gas Treating, Inc., HIGHSULF™ is a trademark of TKK Company.