

How to Increase CO₂ Slip[†]

Ralph H. Weiland and John C. Dingman
Optimized Gas Treating, Inc
15638 Whitewater Lane
Houston, TX 77079

Abstract

In addition to acid-gas equilibrium and reaction-kinetics, amine-treating plant selectivity for H₂S removal (and CO₂ rejection) is also very dependent on the type of equipment used, its configuration, and its operating conditions. Equipment characteristics as factors in selectivity have been largely overlooked by gas treaters.

The reasons for selectivity differences between trays and random packings are discussed in terms of mass transfer fundamentals. An examination of the effect of tray and packing hydraulics on mass transfer leads to a better understanding of equipment mass-transfer performance and appreciation for some of the important, but often overlooked, factors in gas treating.

Examples of high CO₂ natural-gas processing and enrichment of H₂S in regenerator off-gas for Claus plant feed show how CO₂ rejection can be increased by using packing rather than trays. The effect of packing size on CO₂ rejection is also considered, and performance data from a commercial contactor are examined.

1 Introduction

Total acid gas removal processes are relatively simple to design, build, and operate but their economics are frequently poor. The economics of processes capable of selective removal of H₂S and either maximum CO₂ rejection or the production of a treated-gas with a specified CO₂ content (typically 2 to 3%) is usually a major factor in their selection. This is primarily due to the reduction in the amount of CO₂ pickup, which results in lower solvent circulation rates, better quality sulfur plant feed, and concomitantly lower capital and operating costs.

There are two levels of selectivity: (i) *controlled* selectivity in which the goal is to produce a gas with specified maximum levels of both CO₂ and H₂S, and (ii) *maximum* selectivity where the goal is the maximum possible rejection of CO₂ consistent with any maximum H₂S specification on the gas being treated. With a few exceptions, most natural gas specifications fall into the first category wherein a specified degree of selectivity is required. This can be achieved using mixed (so-called formulated) solvents, most of which are based on mixtures of MDEA and another primary or secondary amine used as an activator (or promoter) to adjust the level of CO₂ absorption.

The primary focus of this paper is the second category, where maximum rejection of CO₂ is desired. One of the most typical gas treating applications falling into this category is tail-gas

[†] Paper presented at the Laurance Reid Gas Conditioning Conference, Norman, Oklahoma, February 28, 2001

treating. Another example is for natural gas streams with relatively low total acid gas contents and very high CO₂ to H₂S ratios. This is of particular interest where a higher than normally allowable CO₂ content can be blended with other treated gas streams, without exceeding the CO₂ specification of the combined streams. Single step treatment of high CO₂ to H₂S ratio sour gas streams frequently produces an acid gas too low in H₂S content for a satisfactory Claus plant feed. For such applications, it may be desirable to use a selective first-stage H₂S removal process, followed by a process for bulk CO₂ removal. This arrangement can usually produce an acceptable Claus plant feed and a smaller acid gas that can be flared. An alternative is to upgrade the amine plant regenerator off-gas to produce a super-rich Claus feed or, if the H₂S to CO₂ ratio is extremely low, to concentrate the H₂S into a much smaller volume stream for possible disposal by down-hole reinjection. Off-gas upgrading is an interesting application because the gas being treated is essentially a wet acid gas. The hydrocarbon or inerts content is so low that absorption takes place extremely rapidly, and a very short, well-designed absorber must be used.

In high CO₂-rejection applications, the traditional engineering approach of column over-design is completely unacceptable. First, a column with too many trays or too much packing removes more CO₂ than necessary, and secondly, the additional CO₂ removed by the extra trays can result in failure to meet the H₂S specification altogether. There is an optimal number of trays and an optimal depth of packing that maximizes CO₂ rejection while still meeting the H₂S treating goal. In addition, some types and designs of internals are better than others in these applications.

Interstage cooling can also be effective for increasing CO₂ slip—because CO₂ absorption continues throughout the height of an absorber used for selective H₂S removal. Temperature bulges are often large and continue into the upper region of the column where the high temperatures increase the CO₂ absorption rate. High temperatures and higher-than-normal solvent CO₂ loadings in the top trays of absorbers frequently require larger solvent circulation rates to reduce the size of the temperature bulge on the top trays.

Two of the main difficulties that face the designer are determining the optimal number of actual trays or depth of packing (of a specific type) and deciding on how to provide enough flexibility to be able to handle the inevitable changes in the volumes and acid gas composition experienced over the life of most plant. For the operator of a high-CO₂-rejection facility, the problems are connected with the counterintuitive nature of some of the strategies used to optimize the operation for a specific case on the one hand, and the flexibility needed to adjust operation for new feed gas conditions and bring an off-specification operation back into conformity, on the other.

True mass transfer rate based simulation provides rigorous, more predictive modeling of the process and its columns. As a result, it is an extremely valuable tool for predicting the sensitivity to variations in both design and operating parameters. One of the reasons mass transfer rate based simulation is so valuable is that it makes use of a much more detailed description of the actual mass transfer devices involved. The detailed design and actual number of real trays and packing depth, type, and packing materials in place of theoretical idealizations of stages or HETPs. Use of *ProTreat*[™] simulation results to uncover ways to maximize CO₂ slip and relate the findings to column internals details and actual column structure are described in the various examples presented. Some changes needed are counterintuitive to operating experience.

ProTreat is a trademark of Optimized Gas Treating, Inc.

2 Understanding Selectivity

The key to a basic understanding of selectivity is really quite simple: it is the fact that all alkaline solvents are *thermodynamically* selective towards CO₂ but they are *kinetically* selective towards H₂S. However, if we are to use this understanding to figure out how to increase CO₂ slip (i.e., to improve selectivity) then we must also recognize two other important facts about acid gas-amine systems: (1) CO₂ and H₂S react quite differently in alkaline solution, and (2) their physical absorption rates are controlled by resistances in entirely different phases. How do these three facts relate to selectivity?

When CO₂ dissolves into the solvent, it binds chemically to the amine at *finite* rates of reaction, forming reaction products. At low temperatures, these reaction products are stable and require heat and stripping vapor to decompose them and reverse the reactions. On the other hand, when H₂S dissolves into an amine, it converts immediately to sulfide and bisulfide ions via simple *instantaneous* protonation reactions with hydrogen ions, without directly involving the amine at all. These protonation reactions are immediately reversible and the extent of reversibility depends on solvent alkalinity, *not* reaction kinetics. While CO₂ reacts relatively slowly and H₂S rapidly, the CO₂ forms stable reaction products, whereas, H₂S forms readily-decomposed products in a reaction that depends only on alkalinity. What do these differences imply for relative absorption rates?

If the gas mixture and the solvent are exposed to each other for only a *short* time, H₂S absorbs more rapidly than CO₂ because the instantaneous H₂S reaction keeps the H₂S concentration in the unreacted form low in the liquid and this maintains the driving force high. However, the CO₂ reaction isn't fast enough to prevent its concentration from building up and slowing down its absorption rate. The reaction kinetics have made the process selective towards H₂S. If, on the other hand, we allow the phases to remain in contact for a *long* time, both gases continue to absorb, but as the CO₂ absorbs it consumes amine and reduces the solvent's alkalinity. At some point as the process continues, this reduction in alkalinity becomes too low to keep all the H₂S in a protonated form. Consequently HS⁻ and S⁼ deprotonate and the H₂S starts to desorb. Meanwhile, the CO₂, still driven by the (almost) irreversible reaction, continues to absorb and react. Reaction equilibrium favors keeping CO₂ in solution even to the extent of releasing already-absorbed H₂S if necessary. The trick to controlling selectivity is a combination of manipulating the factors affecting the chemistry, because changing the reaction kinetics profoundly affects the CO₂ absorption rate, and partly through controlling contact times. But there is still a little more to the story.

Although greatly influenced by CO₂ reaction kinetics, the absorption of both gases is also controlled by diffusion. For CO₂, the diffusional resistance is predominantly in the liquid phase, but for H₂S it is in the gas phase. This means that by cleverly selecting the tower internals to favor mass transfer of an acid gas in one phase over the other, it should be possible to alter the relative absorption rates and hence the selectivity. This gives us an additional means to enhance CO₂ slip. So, the secret lies in choosing an amine with the right alkalinity and the right reactivity towards CO₂, allowing gas-liquid contact for the right length of time, and using the right kind of equipment with the right internals. A mass transfer rate model is perfectly suited to dealing with such issues of all-important detail. Equilibrium stage models simply cannot capture these effects.

3 The Mass Transfer Rate Model in a Nutshell

The rigorous, mass transfer rate approach used for all column calculations by *ProTreat* modeling is completely predictive, because it is not dependent on the availability or the need for empirical adjustments to simulate new applications correctly. In fact, there are no

empirical adjustments in the *ProTreat* model. True mass transfer rate modeling is built on five key elements:

- Mass and energy balances *around individual phases* on a tray or in a packed segment
- Conventional thermodynamic phase equilibrium
- Equilibrium across vapor-liquid interfaces
- Effect of chemical kinetics on mass transfer rates, particularly in the liquid phase
- Mass and heat transfer rate models for transport across vapor-liquid interfaces.

There are intricate interrelated effects between these five key elements. They are affected by a variety of chemical and physical, phase and component transport properties such as (i) chemical kinetics, (ii) diffusion coefficients, solvent viscosity, and other heat and mass transport properties, (iii) salting-out effects on acid-gas solubilities, and (iii) the mass transfer characteristics of the actual hardware being used. When a *ProTreat* column simulation is run, the tower is being modeled in full detail as a piece of real equipment, not as an idealization. From a separations standpoint, multi-pass trays perform differently from single-pass trays. Metal packing gives different results from plastics and ceramics. In addition, all solvent properties, including the changes in these properties caused by acid gas loading, affect mass transfer coefficients and thereby influence the actual separation achievable with a specific column under a given set of operating conditions. In the language of process control, a true mass transfer rate simulation uses a distributed parameter model, which, consequently is mechanistic, rich in detail, and fully predictive. This is in contrast to the nonpredictive equilibrium stage approach based on a lumped parameter model that assigns all the physical and chemical complexities to one or two parameters such as stage efficiencies for the acid gases and liquid residence times.

One way to develop a feel for the basics of mass transfer rate modeling of columns is by drawing a comparison with heat exchanger design and analysis. The majority of shell-and-tube heat exchangers, for example, are designed using computer software containing (i) a data base of correlations for tube- and shell-side heat transfer film-coefficients for the exchanger as functions of hydraulics (as measured for example by Reynolds numbers), tube bundle layout, tube and shell passes, and physical arrangements of shell-side baffles, (ii) a data base of relevant fluid properties such as heat capacity, viscosity, thermal conductivity and density, (iii) the heat transfer properties of the tubes. In the simplest case of analyzing an existing exchanger without phase change, the general approach is to determine the overall heat transfer *rate*, or perhaps rates at different positions along the flow paths if properties vary with temperature in some unusual way. What is important to recognize is that the calculation hinges on determining the heat transfer *rate*.

Mass transfer is strongly analogous, but for a number of reasons it is enormously more complex. This is particularly the case when chemical reactions play a key role, as they do in amine treating. It scarcely needs to be pointed out that never is there talk of equilibrium heat exchangers, either with or without efficiency. All heat exchanger calculations are strictly rate-based, and have been for nearly a century. But there are major differences that have made equivalent mass transfer design models much harder to implement. The most serious is the huge number of chemical species involved in mass transfer vs the single temperature variable in heat transfer. A second difference is the inherently nonlinear nature of phase and reaction equilibria compared with the mainly linear heat transfer process. However, with the advent of heavy-duty computing, these differences matter much less and today mass transfer equipment has become as amenable to completely rational design as is heat exchange equipment, both using mass and heat transfer rate based models. The mass and heat transfer rate equations can be solved for complete columns and entire

flowsheets containing multiple columns quite routinely and in computing times that have shrunk to the point where time is no longer an issue. The *ProTreat* model does the mass transfer equivalent of detailed heat exchanger design calculations, but for gas treating with amines.

4 Case Study 1: Selective H₂S Removal from High-CO₂ Natural Gas

This illustration deals with removing H₂S from the high pressure gas stream using the conventional flow scheme shown in Figure 1.

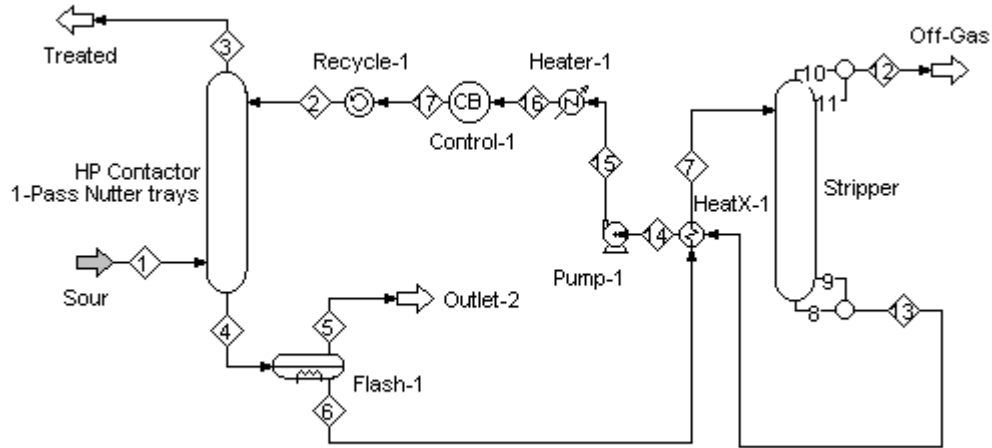

Figure 1 Process Flow Diagram—Case Study 1

The feed streams to the contactor are detailed in Table 1. For the contactor (a 3-ft diameter column containing Nutter trays or Raschig rings), this example demonstrates (i) how trays compare with equivalent depths of a random packing, and (ii) the effect of tray count and packed depth on H₂S removal and CO₂ rejection.

Table 1 Stream Conditions for Case Study 1

	Sour Gas (Inlet 1)	Lean Solvent (Stream 2)
Temperature (°F)	90	110
Pressure (psig)	900	900
Flow (MMSCFD or USgpm)	20	Various
H ₂ S (vol% or loading)	1.0	Various
CO ₂ (vol% or loading)	10.0	Various
Methane (vol% or loading)	85.0	
Ethane (vol% or loading)	4.0	
MDEA (wt%)		45

4.1 Performance of Trays

The effect of tray count on the H₂S content of the treated gas, the percentage CO₂ slipped, and the quality of the off-gas from the regenerator (a potential Claus plant feed) are shown in Figures 2, 3, and 4, respectively, at several solvent rates. Figure 2 shows that the higher solvent flows always produce pipeline quality gas even at low tray counts and that the

treated gas falls off fairly rapidly as the tray count is reduced beyond a certain minimum. Very low solvent flows, however, are incapable of meeting pipeline specifications at all.

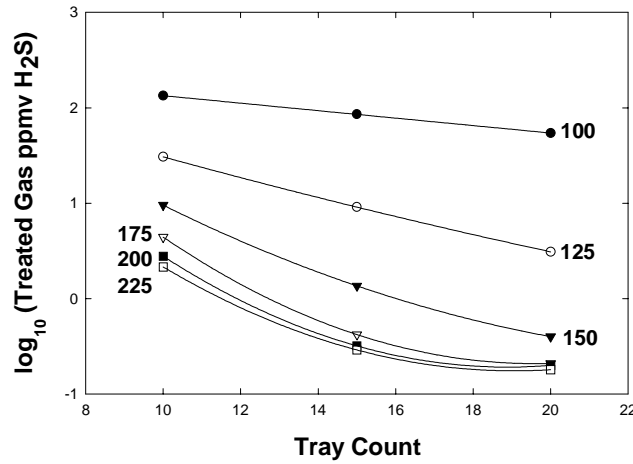

Figure 2 Effect of Number of Trays and Circulation Rate on Treated Gas H₂S Content. Note: The Y-Axis is a Logarithmic Scale

Figure 3 shows that CO₂ slip is rather insensitive to tray count at low solvent rates, and that increasing the solvent rate in order to meet an H₂S specification causes reduced CO₂ slip. As shown in Figure 4, this results in regenerator off-gas of lower and lower quality because CO₂ pickup in the contactor increases. For this particular gas and solvent combination, trays typically slip only 30% to 50% of the CO₂ and produce a marginal quality Claus feed.

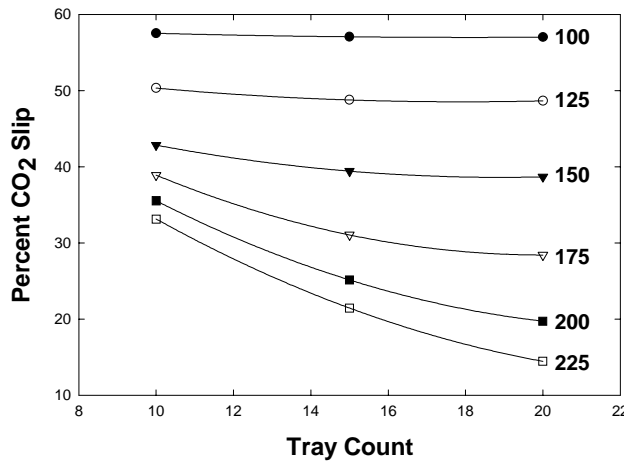

Figure 3 Effect of Tray Count on CO₂ Slip With Circulation Rate (USgpm) as Parameter

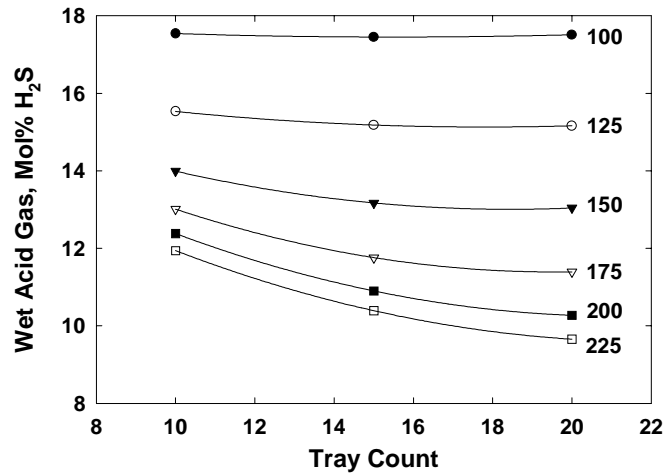

Figure 4 How Increasing Tray Count Lowers Acid Gas Quality. Parameter Is Circulation Rate (USgpm)

4.2 Packing Performance

The effect of packed bed depth on the treated-gas H₂S content, CO₂ slip, and regenerator off-gas quality are shown in Figures 5, 6, and 7, respectively, at several solvent rates.

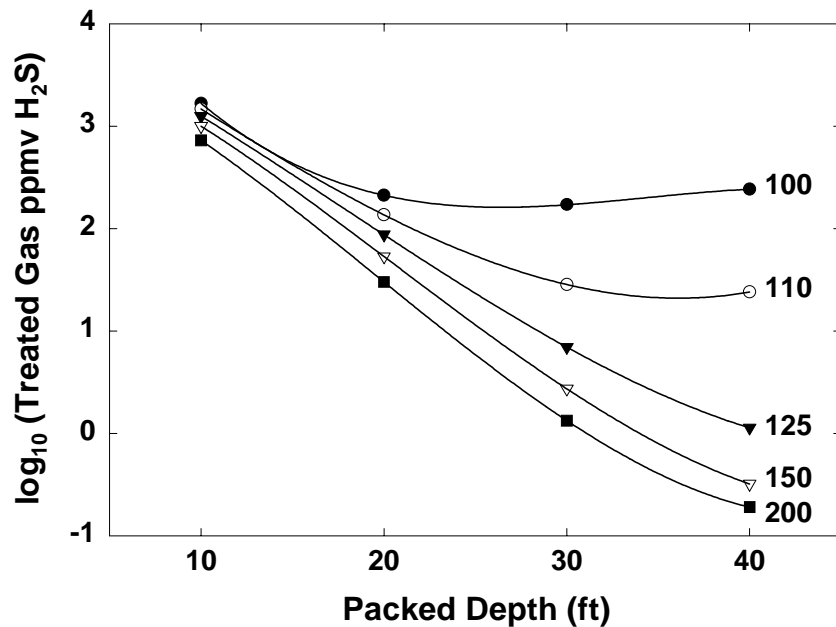

Figure 5 Effect of Packed Bed Depth on Treated Gas Residual H₂S; Parameter is Circulation Rate (USgpm)

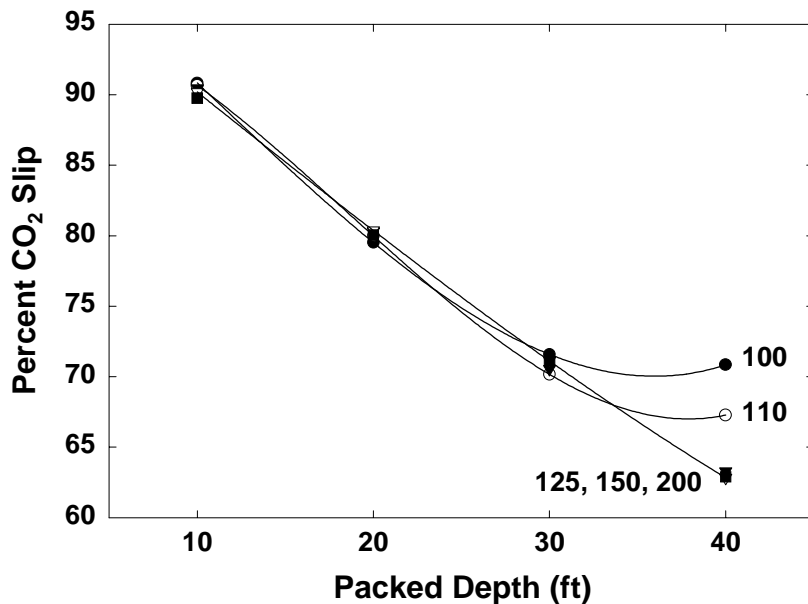

Figure 6 CO₂ Slip Is Improved by Shorter Packed Beds. Circulation Rate (USgpm) is Parameter

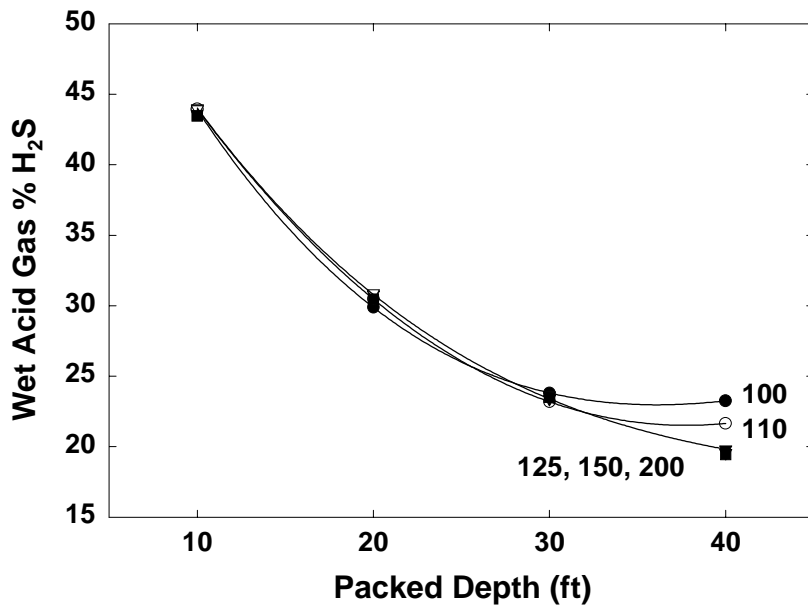

Figure 7 Quality of Wet Acid Gas at Various Circulation Rates (USgpm)

Figure 5 shows that greater depths of packing (2-inch Raschig rings) and the higher solvent flows are needed to produce a treated gas containing less than 4 ppmv H₂S despite the fact that the CO₂ slip with packing (Figure 6) is always very much higher than with trays, typically 70% to 90%. However, this is only first stage treating, and it may be quite satisfactory to leave considerably more H₂S in the treated gas, especially if the second stage regenerator off-gas is to be flared. At low solvent rates, as the packed depth is increased, the sweet gas H₂S content first falls, reaches a minimum, and then begins to

increase. The increase at higher bed depths is caused by increased absorption of CO_2 which prevents H_2S absorption. Figure 7 shows a much improved quality of Claus plant feed (regenerator off-gas H_2S content). Note that the absorber packed bed depth affects enrichment, but solvent rate does not. Solvent rate affects only treated gas purity. Obviously, packing produces a much better quality Claus plant feed.

5 Case Study 2: Regenerator Off-Gas Concentration

This study is concerned with enriching a dilute regenerator off-gas to make it a suitable sulfur-plant feed. The gas being enriched is essentially a wet H_2S - CO_2 stream at 110°F and 10 psig, flowing at 10 MMSCFD. The solvent is 40 wt% MDEA at 120°F . A conventional absorber-regenerator flowsheet is used with a 5-ft diameter regenerator containing 20 two-pass Koch FLEXITRAYS. Note that the regenerator duties for trays and packing were 25 MMBtu/hr and 15 MMBtu/hr, respectively. These were chosen to give similar regenerator reflux ratios under worst-case conditions.

Three feed gas dry-basis analyses are considered: 1, 2, and 5 vol% H_2S with the balance CO_2 and, for the case of 1 vol% H_2S in the feed gas, three solvent rates are examined: 300, 350, and 400 USgpm. Both the trayed and packed contactors were sized for 80% flood as determined for the highest circulation rate.

5.1 Performance of Trays

Figure 8 shows the effect of tray count (Glitsch V-1 trays) and solvent flow on the residual H_2S in the treated gas. The absorber here contained two-pass Glitsch V-1 valve trays in a 5.5-ft diameter shell. Higher solvent rates give lower residual H_2S levels, as expected. However, in each case there is an optimal number of trays at which the H_2S content is minimum. For very small tray counts there is insufficient contact to get to very low H_2S levels and as the number of trays is increased, H_2S pickup improves; however, as the number of trays continues to increase, performance starts to deteriorate. This is because the increased contact results in increased CO_2 pickup which is detrimental to H_2S removal.

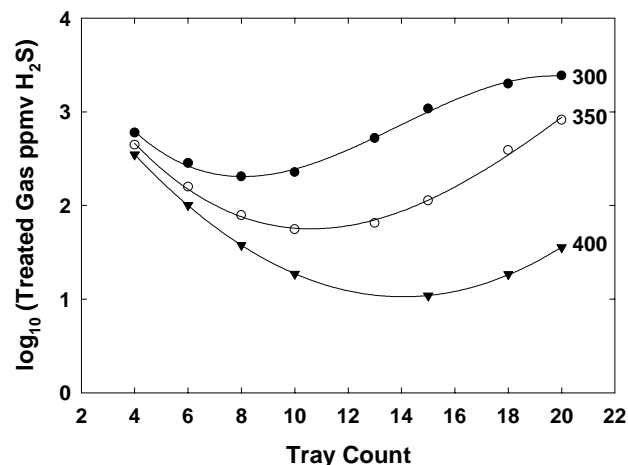

Figure 8 Residual H_2S in Treated Gas at Three Circulation Rates (USgpm). Feed Gas Is Being Enriched From 1% H_2S in CO_2

This can be seen in Figure 9 which shows deteriorating sulfur-plant feed quality as the tray count is increased. Because higher solvent flows can pick up more acid gas, the optimum tray count for best H₂S removal is an increasing function of solvent flow. Of course, the asymptotic limit is zero enrichment which occurs when the tray count and solvent rate becomes high enough for total acid gas pickup.

Figure 10 shows the effect of feed-gas H₂S content on the degree of enrichment as a function of tray count and Figure 11 shows the corresponding treated gas residual H₂S concentration. Again, there is an optimal number of trays for maximum H₂S recovery. However, as expected from the kinetic preference for H₂S vs the thermodynamic selectivity for CO₂, the highest degree of enrichment corresponds to the fewest number of trays, but then the H₂S recovery is poor. Thus, when it comes to tray count, there is always a tradeoff between fractional recovery of H₂S and degree of enrichment.

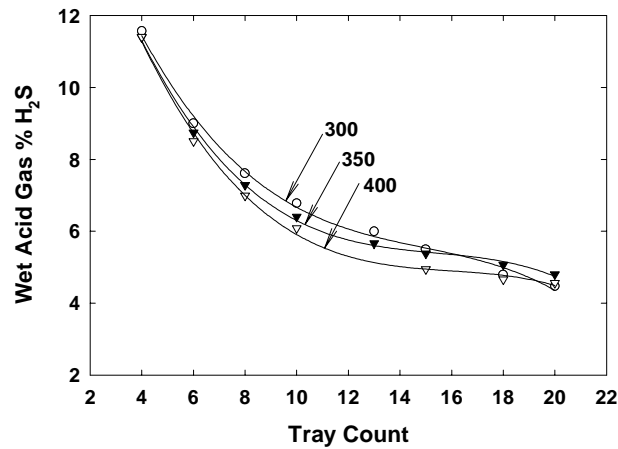

Figure 9 Effect of Tray Count on Enrichment of a 1% H₂S-in-CO₂ Feed Gas at Three Circulation Rates (USgpm)

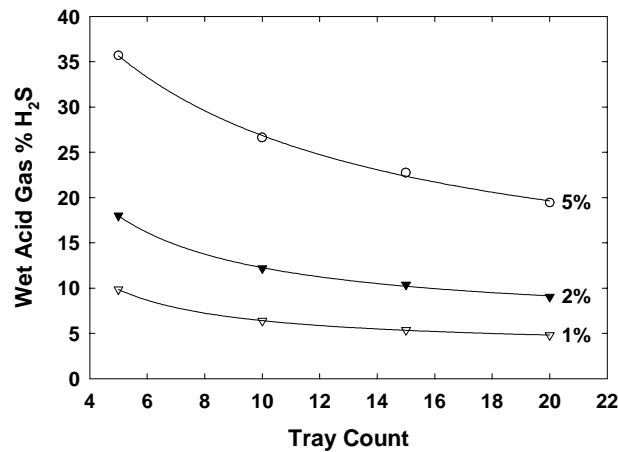

Figure 10 Effect of Tray Count on Enrichment of 1%, 2%, and 5% H₂S Feed Gas at 350 USgpm

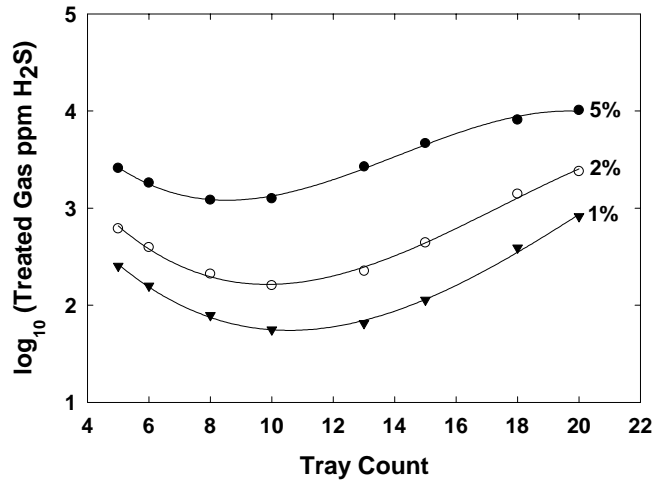

Figure 11 Treated Gas H₂S Content After Enrichment of 1%, 2% and 5% H₂S Feed Streams with Solvent at 350 USgpm. Note: Y-Axis Is Logarithmic

5.2 Performance of Packing

This section discusses the use of 2-inch steel Pall rings in the same acid gas enrichment operation with 40 wt% MDEA. In this case, the tower diameter required for 80% flood at the highest flows was only 4.5 feet. Figure 12 shows that the residual H₂S in the treated gas decreases exponentially with increasing depth of packed bed (note that the y-axis is logarithmic). Solvent circulation rate appears to have very little effect on treated gas quality.

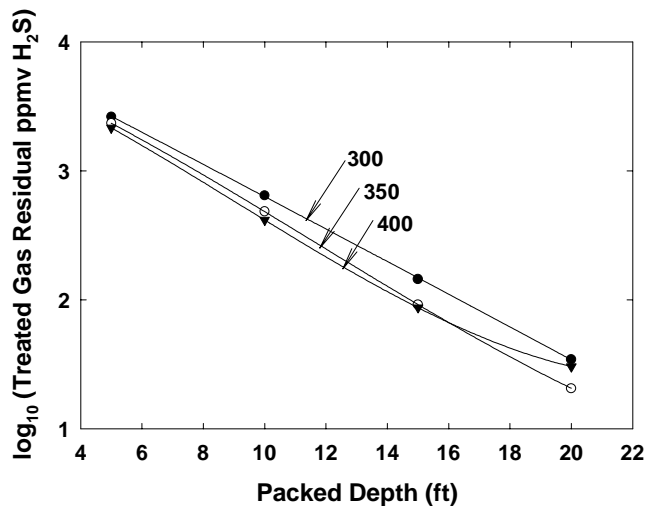

Figure 12 Effect of Bed Depth on Treated Gas Quality After Enrichment at Three Solvent Rates (USgpm)

The quality of the enriched gas stream is shown in Figure 13. The improvement that packing afford over trays is remarkable. Referring to Figure 9, the best that could be achieved under these same circumstances using trays was about a tenfold enrichment. Packing produced a thirty-fold enrichment, taking a stream of 1% H₂S in 99% CO₂ and enriching it to about 30 mol% H₂S. Depending on the solvent rate, trays may or may not achieve a cleaner treated gas; however, the cost is always a tremendously reduced quality of Claus sulfur plant feed.

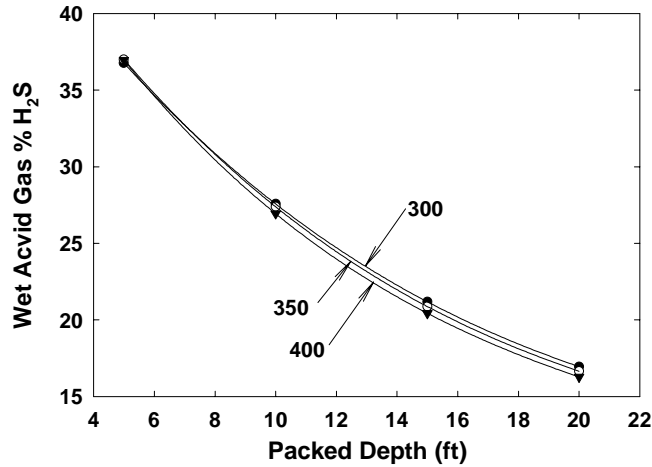

Figure 13 Enriched Wet Acid Gas Stream Obtained at Various Packed Bed Depths and Solvent Rates (USgpm). Feed Gas Was 1% H₂S

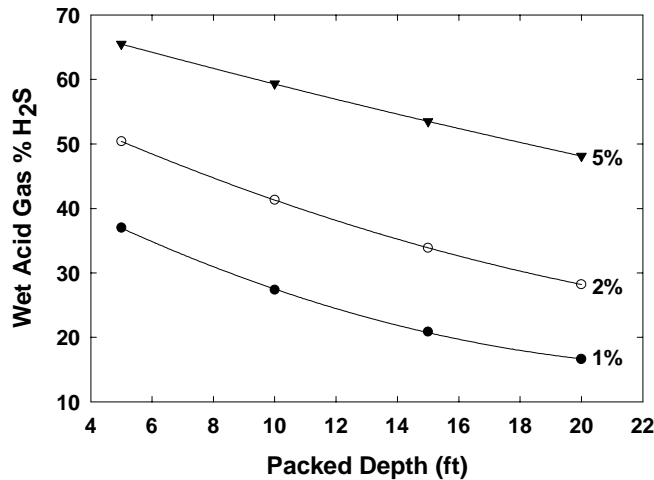

Figure 14 Effect of Packed Bed Depth on Enrichment Achievable From Feed Streams Containing 1%, 2%, and 5% H₂S in CO₂ With Solvent Flow of 350 USgpm

Figures 14 and 15 show the enrichment possible with packing from acid gas streams containing 1%, 2% and 5% H₂S in CO₂, and the concomitant level of treating, respectively. Figure 14 shows that production of sulfur plant feed of outstanding quality from problem off-gas streams is quite achievable. As shown in Figure 15, residual levels of H₂S in the treated gas comparable to those produced with trays can also be reached.

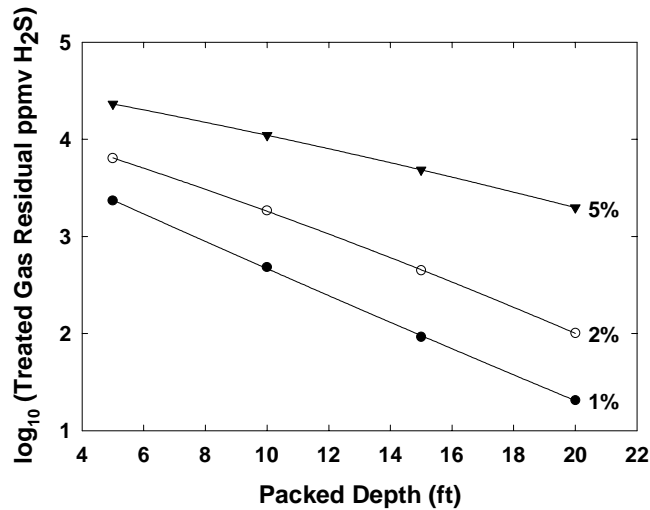

Figure 15 Residual H₂S in Treated Gas for Various Feed Gas H₂S Concentrations in a Packed Contactor With Solvent Flow of 350 USgpm

What has been done here is to take a problem off-gas stream containing levels of H₂S that are hopelessly low for use in a sulfur plant (and probably too high for flaring or to make a sulfur scavenger economic) and produce a very high quality sulfur plant feed. The residue is a very dilute stream of H₂S in CO₂ which must be disposed of, but at these small concentrations of H₂S, both flaring and scavengers become more attractive.

6 Case Study 3: Performance Test of Commercial Absorber

The final example is a commercial contactor removing H₂S and CO₂ with 46.3 wt% DGA. The contactor is 66-in diameter containing 16 Nutter trays on a 2-ft spacing. Fortunately, the plant performance test data (taken in 1982) included measured temperatures on three trays and the tower sump. Table 2 shows the feed stream conditions.

Table 2 Feed Stream Data for Performance Test

	Sour Gas (Inlet 1)	Lean Solvent (Stream 2)
Temperature (°F)	88	119
Pressure (psig)	980	980
Flow (MMSCFD or USgpm)	17.22	
H ₂ S (vol% or loading)	0.38	0.0001
CO ₂ (vol% or loading)	5.82	0.034
Methane (vol% or loading)	93.80	
DGA (wt%)		46.3

This column produced better than 1 ppmv H₂S treated gas, but unfortunately the gas was not analyzed for CO₂. The *ProTreat* simulation gave a treated gas containing 0.05 ppmv H₂S and 1.8 ppmv CO₂. These are very encouraging numbers, particularly in view of the fact that in no sense was the model tweaked into agreement with any of the data—the simulated quality of the treated gas is a pure prediction. Even more impressive, however, is the agreement between the measured and simulated column temperature profiles shown in Figure 16. This plot shows the (unequal) vapor and liquid temperatures on each real tray in the column. The large square symbols are measured data.

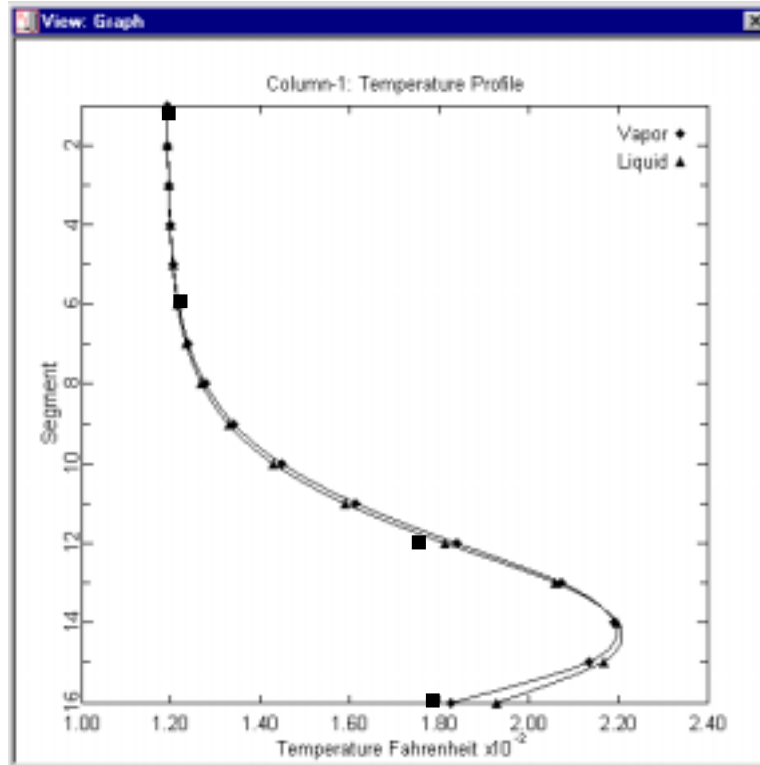

Figure 16 *ProTreat*[™] Simulated Vapor and Liquid Temperature Profiles Compared With Performance Test Data (■)

For this performance test, the column was operating in a severely turned down condition, at 14.4% of jet flood and 11.3% of downcomer flood. Given that the tower was probably originally designed for 80% flood, this represents a 5.5 to 1 turndown ratio. Operation was certainly outside the recommended operating range and there was likely substantial weeping and possibly tray blow-dry. It is again emphasized that the simulated temperature profile is a pure prediction. No parameters have been fine-tuned to achieve agreement and the close match is completely natural.

Acknowledgement

ProTreat was developed with the partial financial support of the Gas Research Institute under Contract Number 5092-222-2409, Dennis Leppin, GRI Project Manager.